

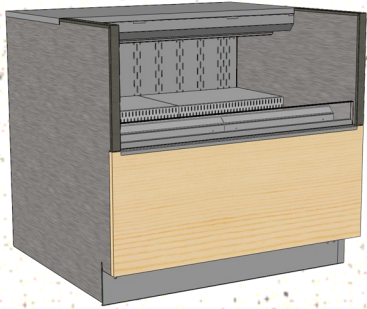

INSTALLATION & OPERATING MANUAL - SCC P/N 20-24002

Important!
See Counter Installation Guide Section In This Manual Before Proceeding With Installation!

SELF-SERVICE REFRIGERATED MERCHANDISERS



Model CO33R With Counter End Panels / Continuous Top & Front

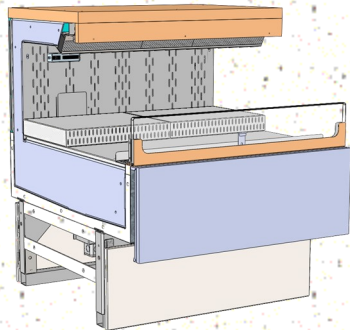

Model CO3034RG.5718 & CO3034RG.5718A With Product Steps

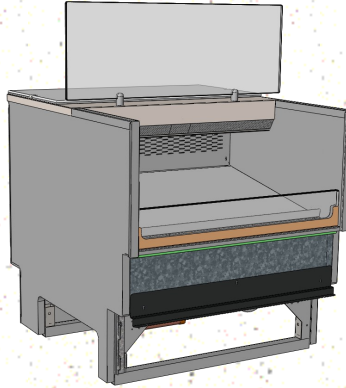

Model CO3436RG.5716 Without Front Panel / Angled Riser & Vertical Sneeze Guard

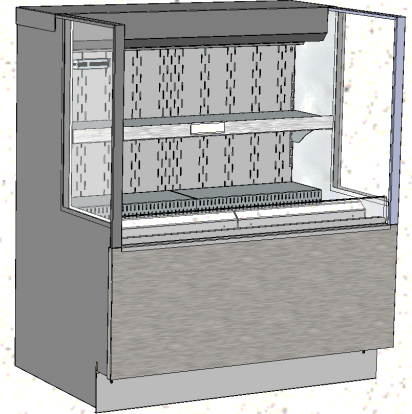

Model CO3324R.7397 (Extended Height Version of CO3324R)

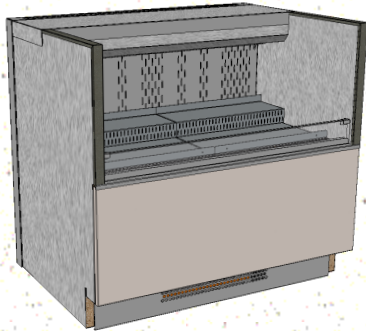

Model CO3324R Front Access Condenser Package

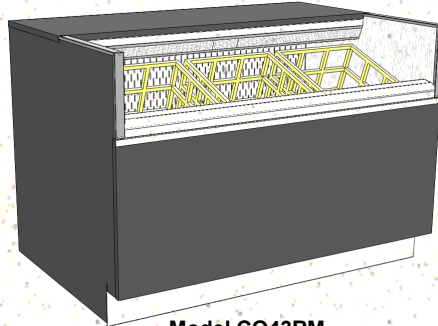

Model CO43RM Under Counter Unit

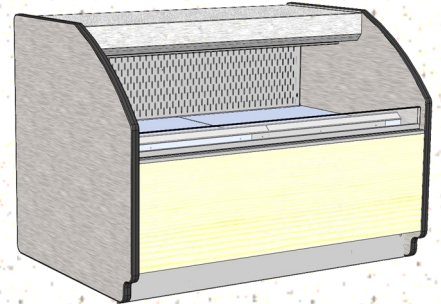

Model CO43R With Curved End Panels

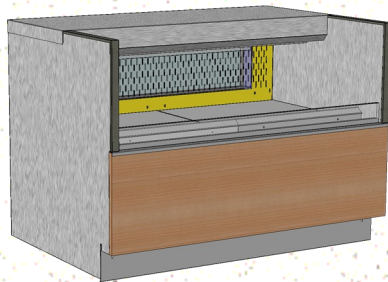

Model CO43R-FS "Free Standing" Unit With Optional Flip-Down Rear Door / Perforated Plenum Rear Door

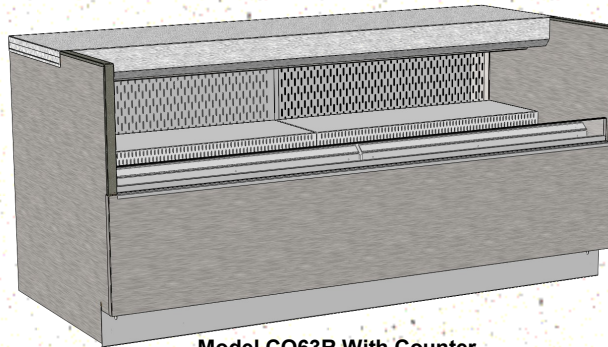

Model CO63R With Counter End Panels And Continuous Top & Front

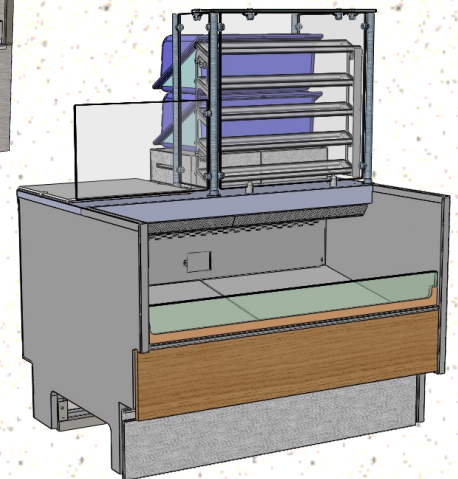

Model CO3436RG.5716, CO4836R.5716 and CO4836RG.5716 (Glycol Unit) Includes SCC's Model BDXXXX Removable Bread Display On Counter (Next To Sneeze Guard)

Model CO33RM (Similar To CO53RM) With Optional Security Cover / Shown Without Customer Supplied Countertop

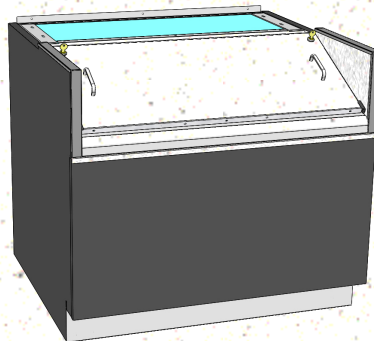

TABLE OF CONTENTS

TABLE OF CONTENTS	2-3
OVERVIEW / TYPE / COMPLIANCE / WARNINGS / PRECAUTIONS / WIRING / PLUGS	4-5
SHIPPING BRACKET REMOVAL / TOE-KICK REMOVAL / REMOVAL FROM SKID / CASE ALIGNMENT	6
CASE ADJOINMENT: SILICONE AND BUTYL APPLICATION / BOLTING ADJOINED UNITS	7
SHIMMING FRAME SUPPORT RAILS / ADJUSTING LEVELERS	8
COUNTER INSTALLATION INFORMATION - FOR MODELS CO33R, CO43R, CO53R & CO63R ...	9
CASE FRONT AND REAR DIMENSIONAL FEATURES	10
SIDE SECTION DIMENSIONAL AND LAYOUT FEATURES	11
CASE TOP AND UNDERSIDE DIMENSIONAL AND LAYOUT FEATURES	12
COUNTER INSTALLATION INFORMATION - FOR MODELS CO3324R, CO4324R, CO5324R & CO6324R	13
CASE FRONT AND REAR DIMENSIONAL FEATURES	14
SIDE SECTION DIMENSIONAL AND LAYOUT FEATURES	15
CASE TOP AND UNDERSIDE DIMENSIONAL AND LAYOUT FEATURES	16
START-UP AND OPERATION: THERMOSTAT / MAIN POWER SWITCH / LIGHTS SWITCH / FILTER	17
PRODUCT PLACEMENT / HONEYCOMB AIRFLOW CONSIDERATION / LOAD LINES	18
MAINTENANCE - TOE-KICKS / LIGHT FIXTURES / NIGHT CURTAIN, HONEYCOMB, THERMOMETER	19
MAINTENANCE - REMOVABLE FRONT PANELS (NON-MAGNETIC)	20
MAINTENANCE - REMOVABLE FRONT PANELS (MAGNETIC)	21
MAINTENANCE - LED LIGHT FIXTURES / LOCATION / REPAIR / REPLACEMENT	22
MAINTENANCE - OPTIONAL NIGHT AIR CURTAIN OPERATING INSTRUCTIONS	23
MAINTENANCE - ELECTRICAL ACCESS AND COMPONENTS	24
MAINTENANCE - REAR COMPONENT LAYOUT (MODEL CO3436RG.5716 ONLY)	25
MAINTENANCE - OPTIONAL SECURITY COVER / OPTIONAL FLIP-DOWN DOOR	26
MAINTENANCE - MODEL CO4836R.5716 & CO4836RG.5716 / REMOVABLE BREAD DISPLAY...	27
REFRIGERATION - EVAPORATOR AREA: MODELS CO33R / CO43R / CO4324R / CO53R / CO63R	28
REFRIGERATION - EVAPORATOR AREA: MODELS CO43RM / CO63RM (AND SIMILAR UNITS)	29
REFRIGERATION - EVAPORATOR AREA: MODELS CO3434RG.5716, CO3436RG.5716, CO3034RG.5718 & CO3034RG.5718A	30
REFRIGERATION - CONDENSATE PACKAGE ACCESS (SCREW REMOVAL REQUIRED)	31
REFRIGERATION - REAR CONDENSATE PACKAGE ACCESS (NO SCREW REMOVAL REQUIRED)	32
REFRIGERATION - FRONT CONDENSATE PACKAGE ACCESS (NO SCREW REMOVAL REQUIRED)	33
REFRIGERATION - CONDENSATE PACKAGE ILLUSTRATED PARTS BREAKDOWN (CO**R) ...	34
REFRIGERATION - CONDENSATE PACKAGE (CO3436RG.5716 / CO3034RG.5718 / CO3034RG.5718A)	35
GENERAL CLEANING (TO BE PERFORMED BY STORE PERSONNEL) - EXTERNAL	36
GENERAL CLEANING (TO BE PERFORMED BY STORE PERSONNEL) - INTERIOR	37
GENERAL CLEANING (BY TRAINED SERVICE PROVIDERS ONLY)	38

TABLE OF CONTENTS, CONTINUED

TRUBLESHOOTING (TO BE PERFORMED BY STORE PERSONNEL)	39-40
TRUBLESHOOTING (TO BE PERFORMED BY TRAINED SERVICE PROVIDERS ONLY)	41-42
TRUBLESHOOTING (BY TRAINED SERVICE PROVIDERS ONLY) - CONDENSING SYSTEM	43
TRUBLESHOOTING (BY TRAINED SERVICE PROVIDERS ONLY) - EVAPORATOR SYSTEM	44
PREVENTIVE MAINTENANCE (TO BE PERFORMED BY TRAINED SERVICE PROVIDERS ONLY)	45
PREVENTIVE MAINTENANCE: HONEYCOMB AIR DIFFUSERS (TO BE PERFORMED BY TRAINED SERVICE PROVIDERS ONLY)	46
SERIAL LABEL & LOCATION / TECHNICAL INFORMATION / ADD'L INFORMATION	47
CAREL® CONTROLLER - PROGRAMMING THE INSTRUMENT.....	48
CAREL® CONTROLLER - USER INTERFACE, SUMMARY TABLES OF ALARMS & SIGNALS	49
CAREL® CONTROLLER - Summary Table of Operating Parameters (After Programming Key) ..	50
SCC TECHNICAL SERVICE CONTACT INFORMATION & LIMITED WARRANTY	51

Models Represented In This Operating Manual*

CO33R CO43R CO53R CO63R CO3324R, CO4324R, CO5324R and CO6324R (24" DEEP VERSION OF CO33R, CO43R, CO53R and CO63R) / CO43R-FS (FREE-STANDING WITH OPTIONAL FLIP-DOWN REAR DOOR) / CO33RM CO43RM CO53RM CO63RM (UNDER COUNTER MILK CRATE UNITS / REFRIGERATED MILK DISPLAYS); AKA CO33RM-UC CO43RM-UC CO63RM-UC. ALSO, CO3434RG.5716 CO3034RG.5718 CO3034RG.5718A CO3436RG.5716 CO4836R.5716 CO4836RG.5716 / CO4324R.7391.

* This Manual May Also Be Applicable To Models Not Listed Herein.

OVERVIEW

- These Structural Concepts merchandisers are designed to merchandise packaged products at 41 °F (5 °C) or less product temperatures.
- Product must be pre-chilled to 41 °F (5 °C) or less prior to being placed in merchandiser.
- Cases should be installed and operated according to this operating manual's instructions to ensure proper performance. Improper use will void warranty.

TYPE I vs. TYPE II ENVIRONMENTAL CONDITIONS

This unit is designed for the display of products in ambient store conditions where temperature and humidity are maintained within a specific range.

- Type I display refrigerators are intended for use in an area where environmental conditions are controlled and maintained so that the ambient temperature does not exceed 75 °F (24 °C) and 55% maximum humidity.

- Type II display refrigerators are intended for use in an area where environmental conditions are controlled and maintained so that the ambient temperature does not exceed 80 °F (27 °C) and 55% maximum humidity.
- If unsure if your unit is Type I or II, see tag next to serial label.

COMPLIANCE

- Performance issues when in violation of applicable NEC, federal, state and local electrical and plumbing codes are not covered by warranty. See below.

WARNINGS

- This sheet contains important warnings to prevent injury or death. Please read carefully!

PRECAUTIONS, CORD/PLUG MAINTENANCE & WIRING DIAGRAM INFORMATION

- See next page for **PRECAUTIONS, CORD/PLUG MAINTENANCE** and **WIRING DIAGRAM** information.



COMPLIANCE
This equipment **MUST** be installed in compliance with all applicable NEC, federal, state and local electrical and plumbing codes.



WARNING
Risk of electric shock. Disconnect power before servicing unit.
CAUTION! More than one source of electrical supply is employed with units that have separate circuits.
Disconnect ALL ELECTRICAL SOURCES before servicing.



WARNING
Hazardous moving parts. Do not operate unit with covers removed.
Fan blades may be exposed when deck panel is removed.
Disconnect power before removing deck panel.

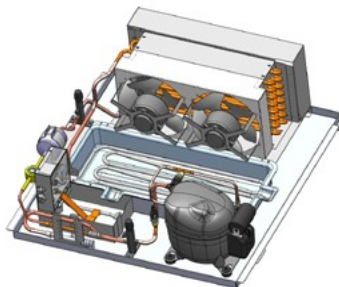

CAUTION! IF YOUR UNIT IS SELF-CONTAINED, YOU MUST CHECK CONDENSATE PAN POSITION & PLUG!
Water on flooring can cause extensive damage!
Before powering up unit, check and confirm that:

- Condensate pan is **DIRECTLY UNDER** condensate drain.
- Condensate pan plug is securely plugged into receptacle.
- Overflow pan has plug connected to its box. Units with optional Clean Sweep® **MUST HAVE** two plugs connected.



WARNING: This product can expose you to chemicals, including Urethane (Ethyl Carbamate), which are known to the state of California to cause cancer and birth defects or other reproductive harm. For more information go to P65Warnings.ca.gov.

PRECAUTIONS

- Following are important precautions to prevent damage to unit or merchandise.
- Please read carefully!
- See previous page for specifics on **OVERVIEW**, **TYPE**, **COMPLIANCE** and **WARNINGS**.

WIRING DIAGRAM

- Each case has its own wiring diagram folded and in its own packet.
- Placement on case varies (near ballast box, field wiring box, raceway cover, or other related location).

REFRIGERANT DISCLOSURE STATEMENT

- This equipment is prohibited from use in California with any refrigerants on the "List of Prohibited Substances" for that specific end-use, in accordance with California Code of Regulations, title 17, section 95374.
- This disclosure statement has been reviewed and approved by Structural Concepts and Structural Concepts attests, under penalty of perjury, that these statements are true and accurate.



CAUTION! LAMP REPLACEMENT GUIDELINES
 Fluorescent lamps have been treated to resist breakage and must be replaced with similarly treated lamps.
 If using LED lamps, they must reflect specific size, shape and overall design. Any replacements must meet factory specifications.

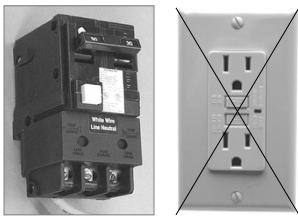

CAUTION! GFCI BREAKER USE REQUIREMENT
 If N.E.C. (National Electric Code) or your local code requires GFCI (Ground Fault Circuit Interrupter) protection, you **MUST** use a GFCI breaker in lieu of a GFCI receptacle.



CAUTION! POWER CORD AND PLUG MAINTENANCE
 Risk of electric shock. If cord or plug becomes damaged, replace only with cord and plug of same type.



CAUTION! ADVERSE CONDITIONS / SPACING ISSUES

- Performance issues caused by adverse conditions are **NOT** warranted.
- Keep end panels tightly joined or at least 6" away from structures to prevent condensation. Keep rear panel at least 6" from wall/structure.
- Unit must be kept at least 15-feet from exterior doors, overhead HVAC vents or any air curtain disruption to maintain proper temperatures.
- Unit must not be exposed to direct sunlight or any heat source.
- Self-contained unit clearance: 6" min. air intake / 6" min. air discharge.



CAUTION!
DO NOT RELY ON THERMOMETERS OR THERMOSTATS FOR ACTUAL PRODUCT (FOOD) TEMPERATURES.

- Thermometers & thermostats reflect air temperatures **ONLY**.
- For **ACTUAL** food temperatures, use calibrated food thermometers.

1. Removing Shipping Brackets Attached To Skid

- Remove screws holding case shipping brackets to skid.
- Remove case shipping brackets from skid.
- See illustrations at right. Note: Shipping brackets will vary in size, shape, material and location depending upon case type and model.

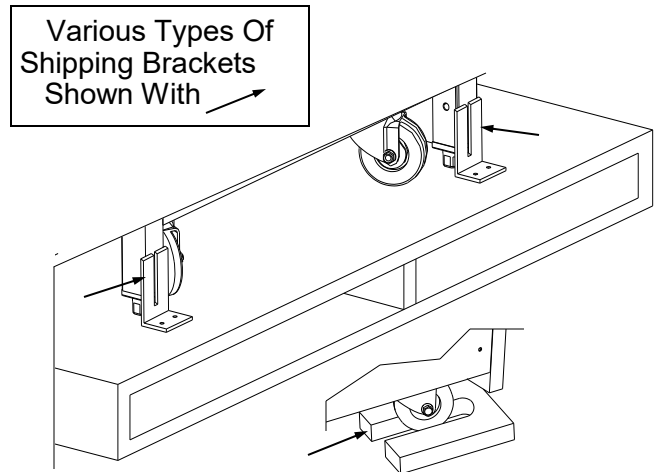

2. Remove Front / Rear Toe-Kicks Before Removing From Skid

- Toe-kicks are normally shipped separately.
- If toe-kicks are attached to case, they must be removed.
- Toe-kicks may be attached to case via slot /magnet method.
- Remove toe-kick by pulling away from lower magnet and lifting up and off hooks.
- No screw removal is required.
- See illustrations at mid-right.

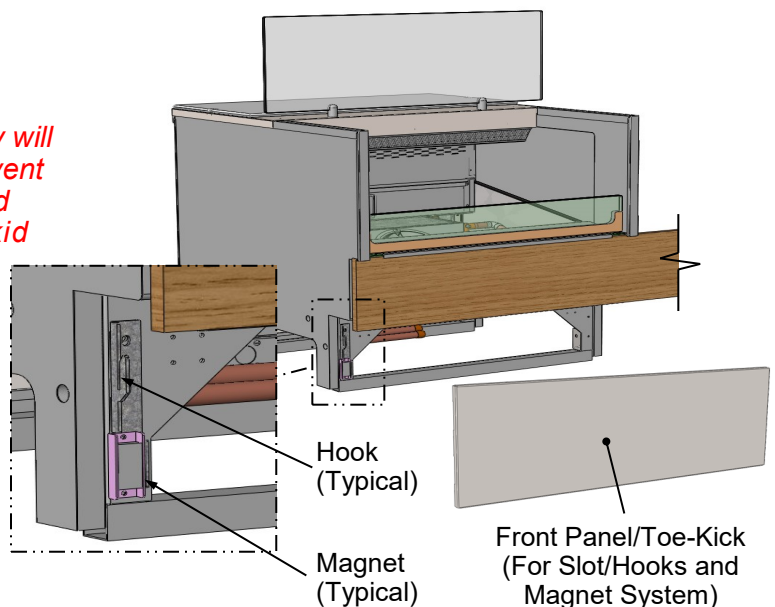

3. Remove Case From Skid

- **Important!** If case is shipped with levelers, they will be in the **DOWN** position (for stability). To prevent damage to the case, all levelers must be raised **ALL THE WAY UP** before moving unit off skid and into position.
- To prevent damage, support case while sliding it toward edge of skid).
- IF NO CASTERS ARE ON SKID, tip case slightly back and slide skid from underside of case. When case is at edge of skid, carefully lower to floor (so two levelers rest on floor).
- IF CASTERS ARE ON CASE, it may be rolled off skid via ramp (as shown in lower-right illustration).
- Carefully slide skid out from under case.
- After removal of case from skid, place into position.
- Note: Illustration below-right may not reflect your particular model or options).

Note: View at Right Shows Partially Disassembled Case For Illustrative Purposes Only.

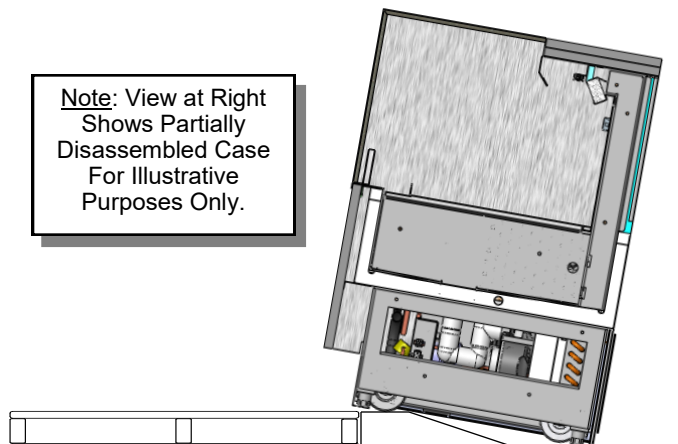

4. Position/Align Case Alongside Other Cases

- If lineup requires it, be sure to position/align your case alongside adjoining cases before adjusting levelers or shimming frame support rails.
- This may require the repositioning of the case you are installing or the already positioned cases.

CASE ADJOINMENT: SILICONE AND BUTYL APPLICATION / BOLTING ADJOINED UNITS

Case Adjoiment

- >> Warranty is void if improper urethane/sealant is used.
- >> Lay generous beads of caulk/sealant as specified.

A. Prior To Adjoiment - Apply Industrial Butyl Caulk at Center of Uprights

- Lay a generous bead of industrial grade urethane/sealant at center of uprights (in non-visible areas).
- This urethane adhesive prevents refrigerated air from escaping between cases (causing condensation and reducing refrigeration efficiency) as well as preventing ants or other insects from entering case.
- See illustration below.

B. Adjoining Cases - Using Bolts and Nuts

- Use appropriately sized nuts and bolts for each hole.
- #1 - Hole is accessible at underside of top surface support.
- #2 - Holes are accessible through rear plenum and behind honeycomb air diffuser.
- #3 - Holes are accessible at underside of decking.

Decking must be removed to attach bolts/nuts.
 #4 - Holes are accessible at base frame (through front of case after front toe-kicks have been removed).

- Tighten nuts securely (but do not over-tighten).
- See accompanying illustration below.

C. After Adjoiment - Apply Food Grade Silicone Sealant To Inner And Outer Seams

- After all nuts/bolts are securely attached to case, apply a generous bead of food grade silicone sealant at both inner and outer adjoiment seams.
- When properly applied, this food grade silicone sealant will prevent water from seeping between cases (into the case or to the floor) as well as crumbs or other residue from entering between case seams.
- See illustrations below.

>> You must reattach toe-kick and decking after case adjoiment process is complete.

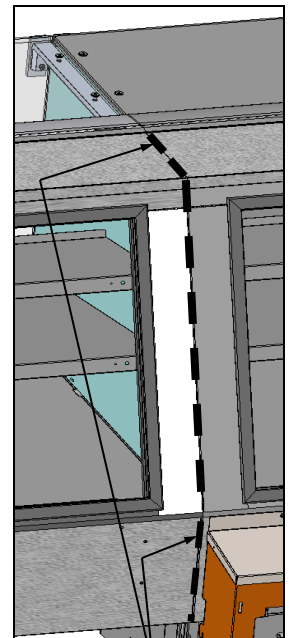

Outer Sanitation Bead To Be Applied At Outer Adjoiment Seams (Shown Above In Random Model)



Industrial Grade Urethane Adhesive (For Refrigeration Bead Applications)



Silver, Black or Clear Silicone Sealant Conforming To NSF/ANSI 51 Specifications (For Sanitation Bead Applications)

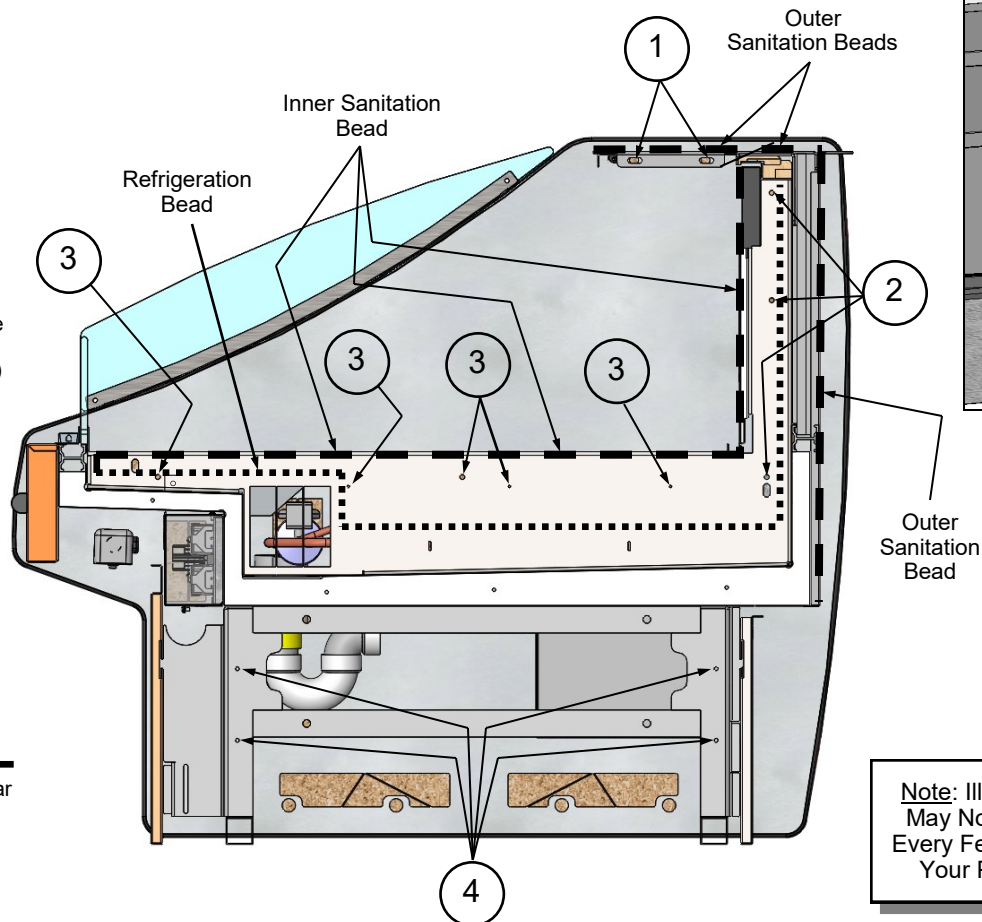

Note: Illustrations Shown May Not Exactly Reflect Every Feature or Option of Your Particular Case.

SHIMMING FRAME SUPPORT RAILS / ADJUSTING LEVELERS

1. Cases With Frame Support Rails: Shim

- Illustration at top-left shows case with frame support rails.
- Shims will be provided on cases with frame support rails.
- Use shims to level case.

2. Cases With Levelers: Adjust

- **Important!** For cases with casters, after case is in proper position, levelers must then be **LOWERED** to floor.

- Adjust case so it is level and plumb.
- You may need to remove front and/or rear toe-kick to access levelers.
- Use adjustable wrench (and possibly a pry bar) to adjust leveler.
- Do not use pry bar on toe-kick (it may buckle).
- Do not use pry bar on end panel (it may chip).
- Use pry bar **ONLY** on base frame to avoid damaging case.
- Use a block to reach base frames with pry bar.
- See below-right illustrations.

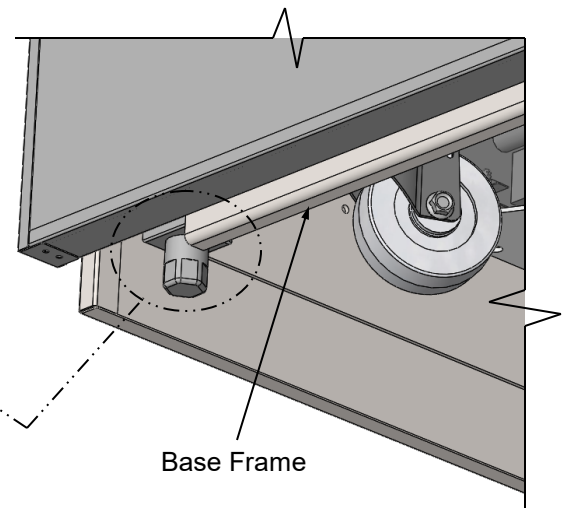
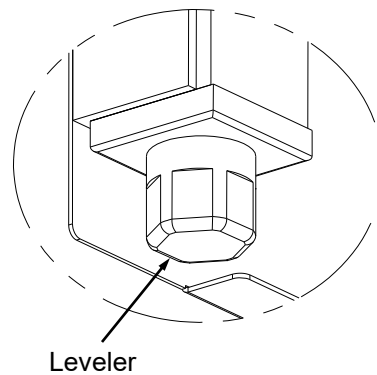
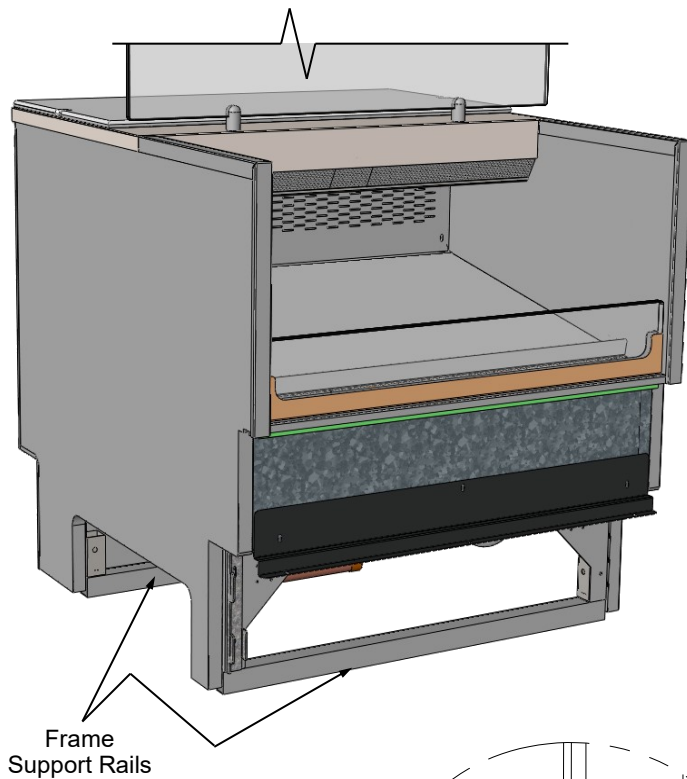

**THE FOLLOWING
COUNTER INSTALLATION
INFORMATION IS ONLY
APPLICABLE TO
MODELS CO33R, CO43R,
CO53R and CO63R
“UNDER-COUNTER”
UNITS**

**NOTE: ANY REVISIONS
TO THIS INFORMATION
MUST ALSO MADE TO
SCC P/N 20-50848**

CASE FRONT AND REAR DIMENSIONAL FEATURES

NOTE: THE FOLLOWING COUNTER INSTALLATION INFORMATION PERTAINS ONLY TO MODELS CO33R, CO43R, CO53R and CO63R "UNDER-COUNTER" UNITS

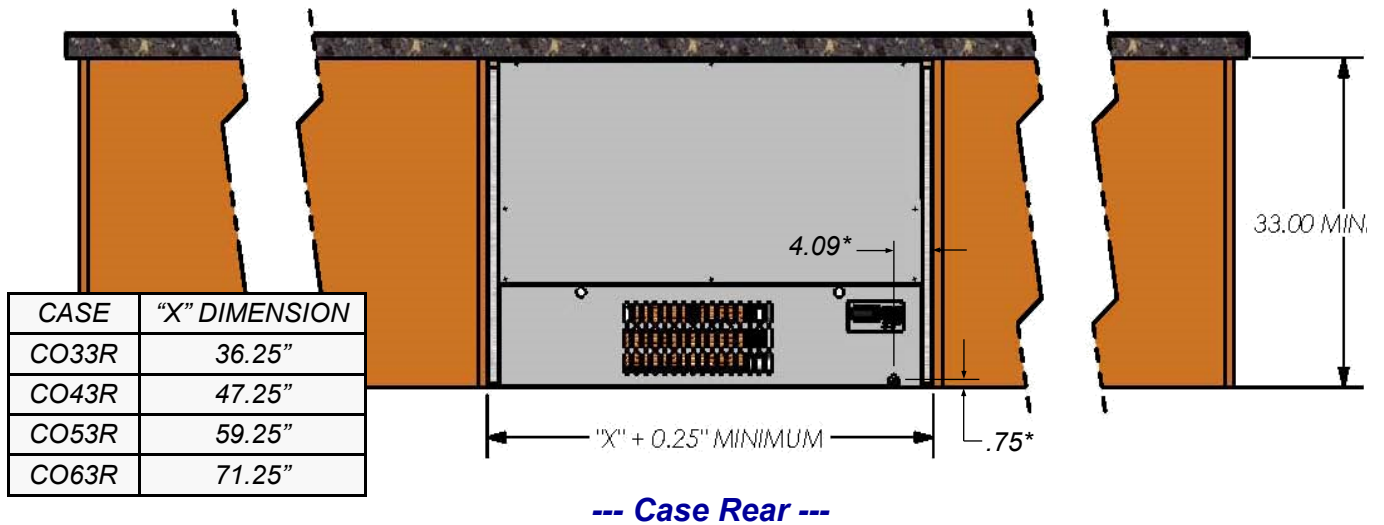
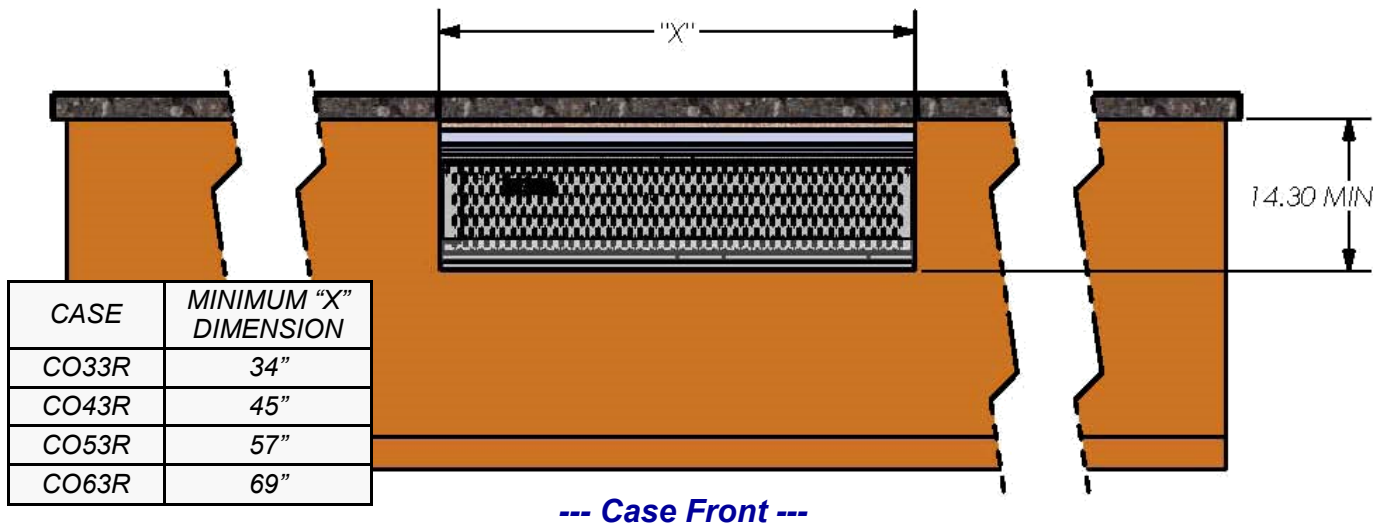

* *Note:* A 6-foot power cord is supplied and exits the display through the lower rear panel (as shown immediately above). Refer to your particular model's specification sheet for electrical requirements and plug configuration.

SIDE SECTION DIMENSIONAL AND LAYOUT FEATURES

NOTE: THE FOLLOWING COUNTER INSTALLATION INFORMATION PERTAINS ONLY TO MODELS CO33R, CO43R, CO53R and CO63R "UNDER-COUNTER" UNITS



--- Side Section ---

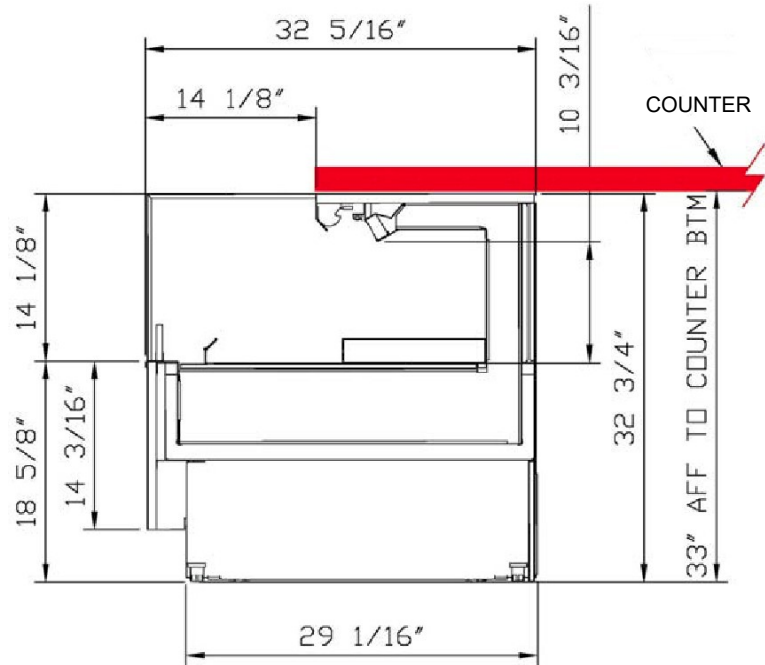

--- Side Section With Full Dimensions ---

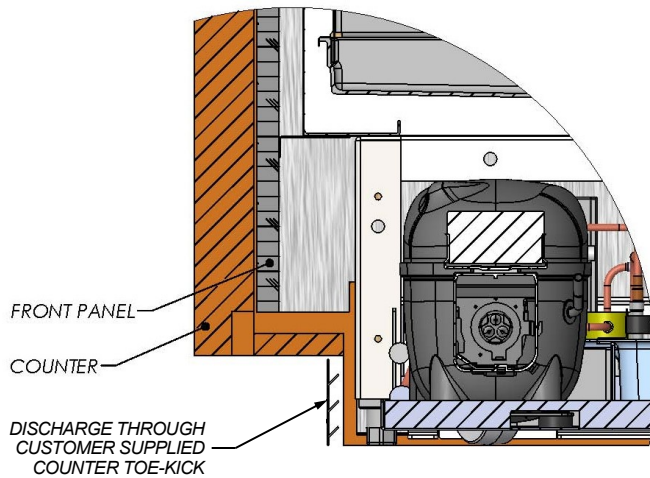

--- Side Section Without O.E.M. Toe-Kick ---

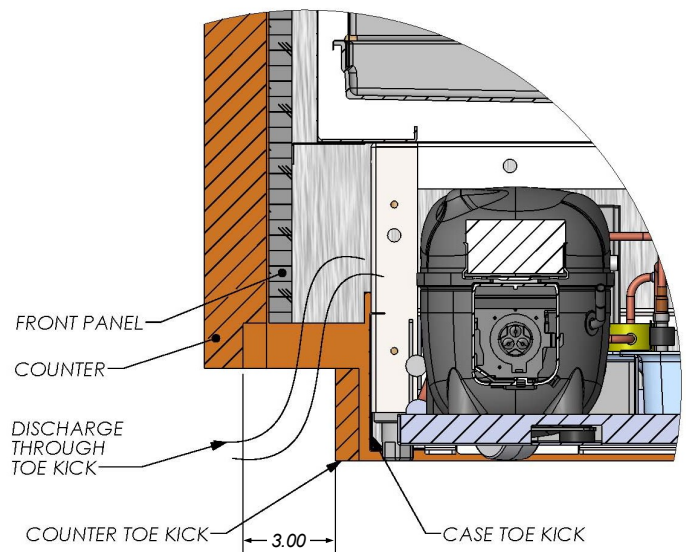

--- Side Section With O.E.M. Toe-Kick ---

CASE TOP AND UNDERSIDE DIMENSIONAL AND LAYOUT FEATURES

NOTE: THE FOLLOWING COUNTER INSTALLATION INFORMATION PERTAINS ONLY TO MODELS CO33R, CO43R, CO53R and CO63R "UNDER-COUNTER" UNITS

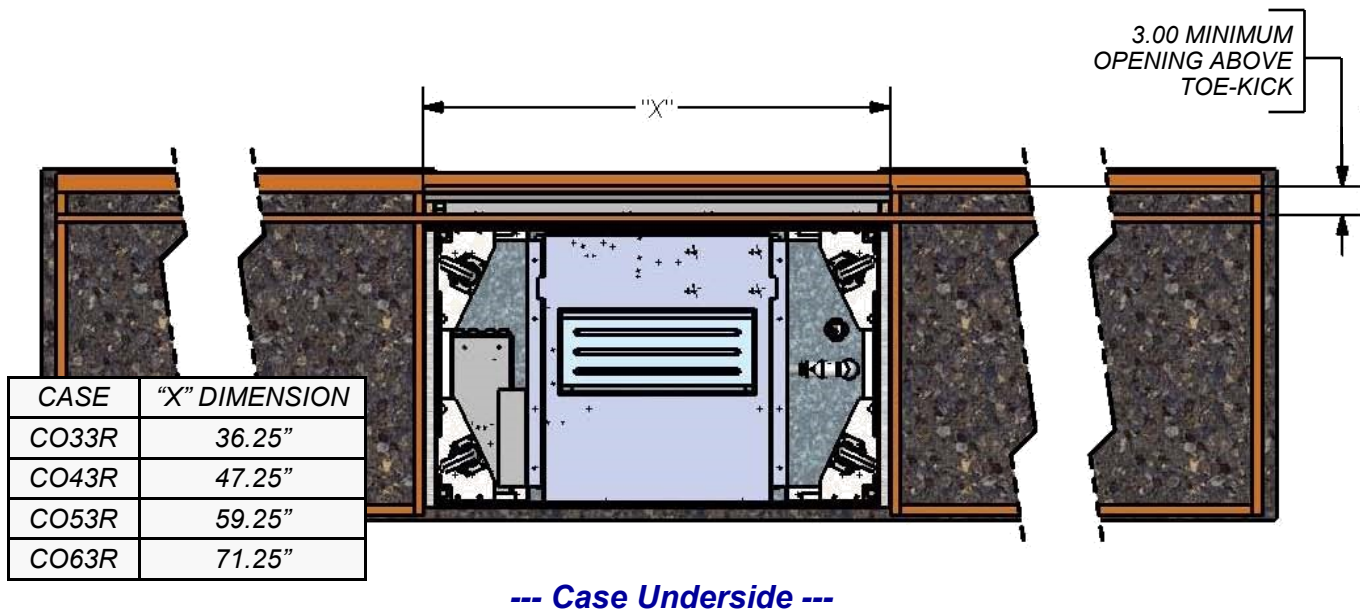
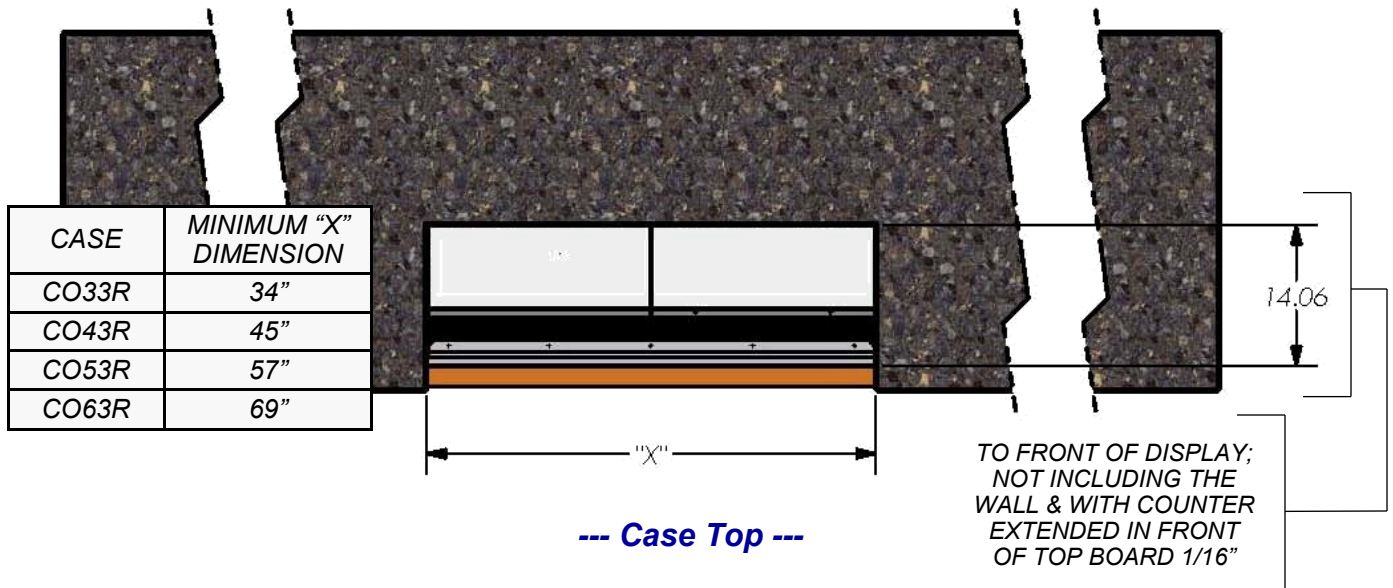

**THE FOLLOWING COUNTER
INSTALLATION IN-
FORMATION IS ONLY
APPLICABLE TO
MODELS CO3324R,
CO4324R, CO5324R and
CO6324R**

**NOTE: ANY REVISIONS
TO THIS INFORMATION
MUST ALSO MADE TO
SCC P/N 20-50862**

CASE FRONT AND REAR DIMENSIONAL FEATURES

NOTE: THE FOLLOWING COUNTER INSTALLATION INFORMATION PERTAINS ONLY TO MODELS CO3324R, CO4324R, CO5324R and CO6324R

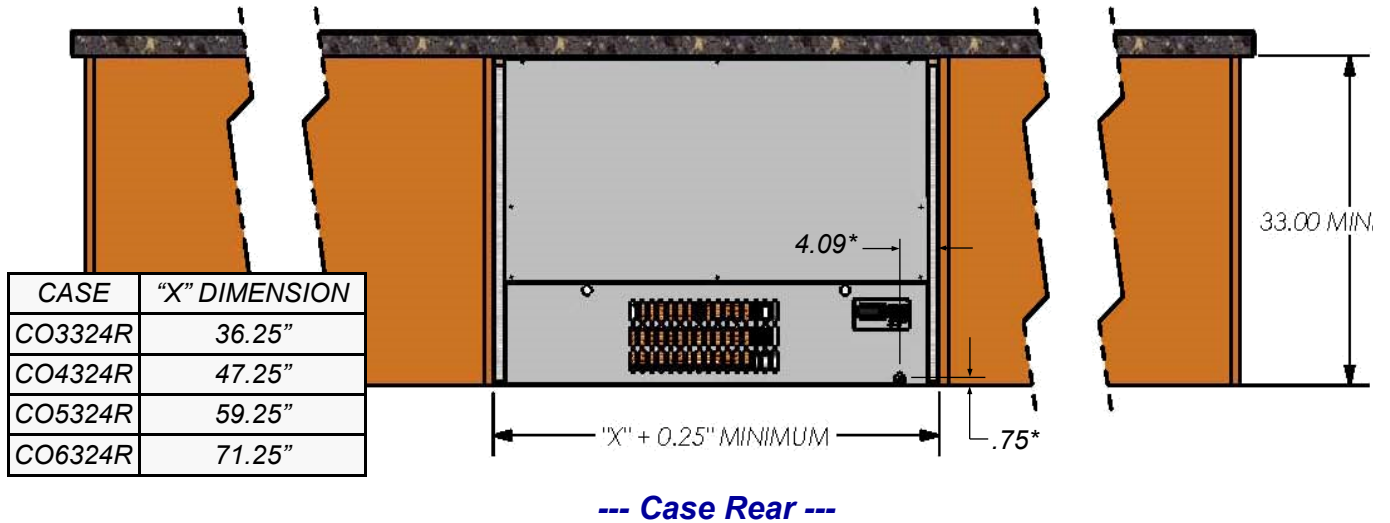
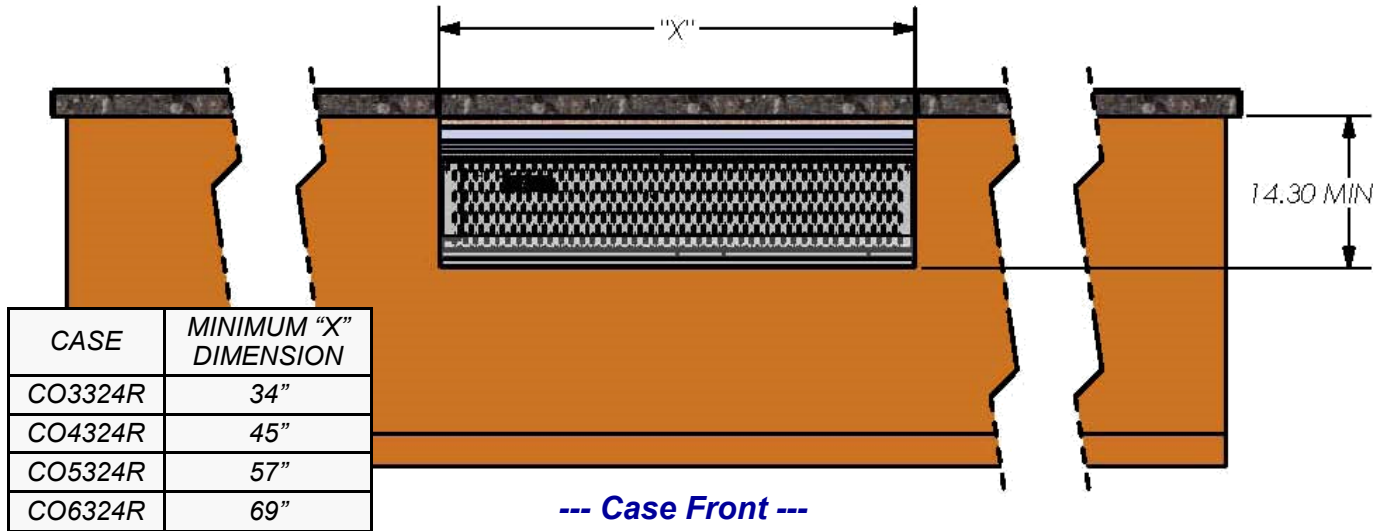

* *Note: A 6-foot power cord is supplied and exits the display through the lower rear panel (as shown immediately above). Refer to your particular model's specification sheet for electrical requirements and plug configuration.*

SIDE SECTION DIMENSIONAL AND LAYOUT FEATURES

NOTE: THE FOLLOWING COUNTER INSTALLATION INFORMATION PERTAINS ONLY TO MODELS CO3324R, CO4324R, CO5324R and CO6324R

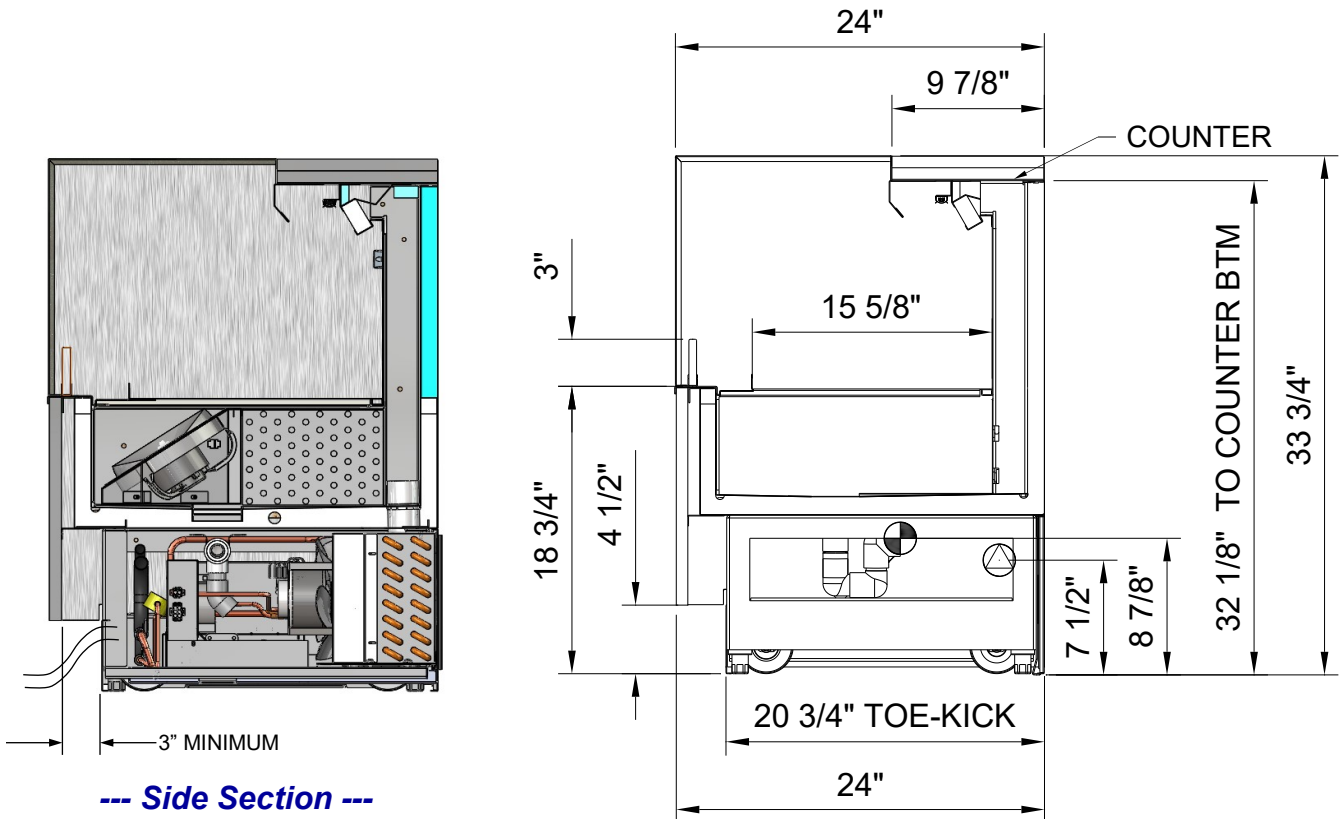

--- Side Section ---

--- Side Section With Full Dimensions ---

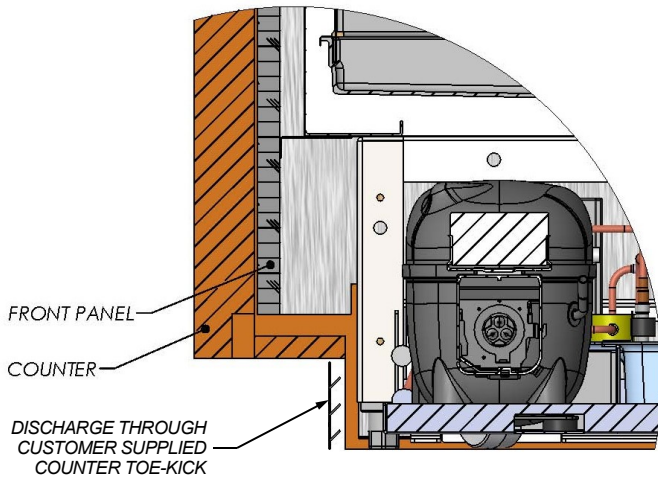

Note: Above Illustration May Not Exactly Reflect Every Feature or Option of Your Particular Case

--- Side Section Without O.E.M. Toe-Kick ---

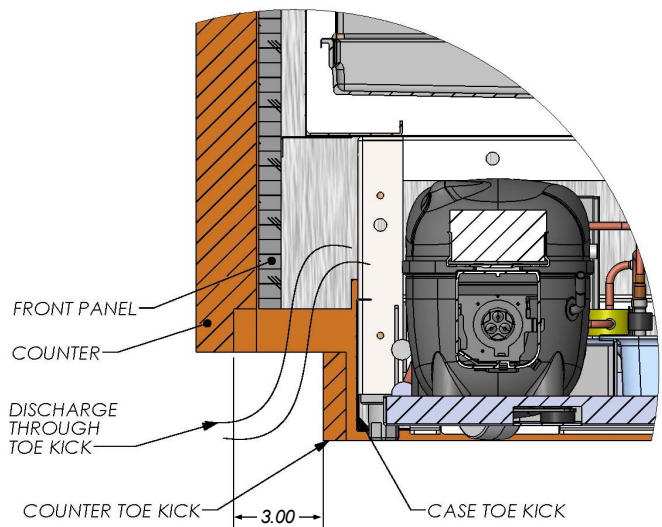

Note: Above Illustration May Not Exactly Reflect Every Feature or Option of Your Particular Case

--- Side Section With O.E.M. Toe-Kick ---

CASE TOP AND UNDERSIDE DIMENSIONAL AND LAYOUT FEATURES

NOTE: THE FOLLOWING COUNTER INSTALLATION INFORMATION PERTAINS ONLY TO MODELS CO3324R, CO4324R, CO5324R and CO6324R

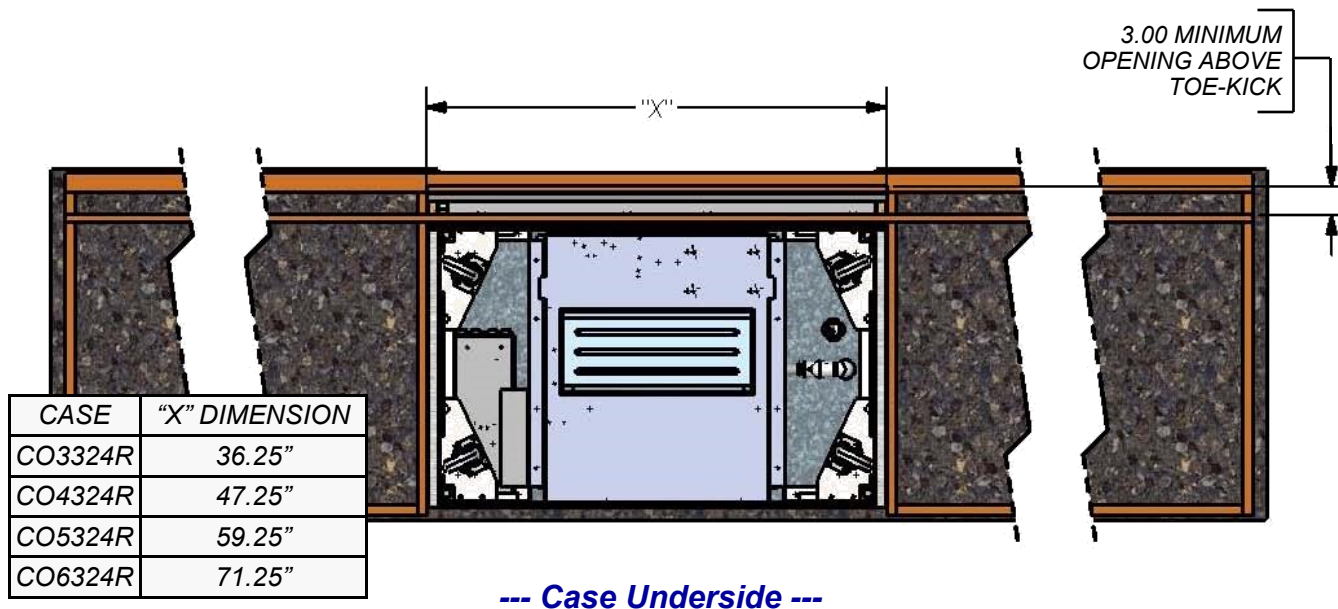
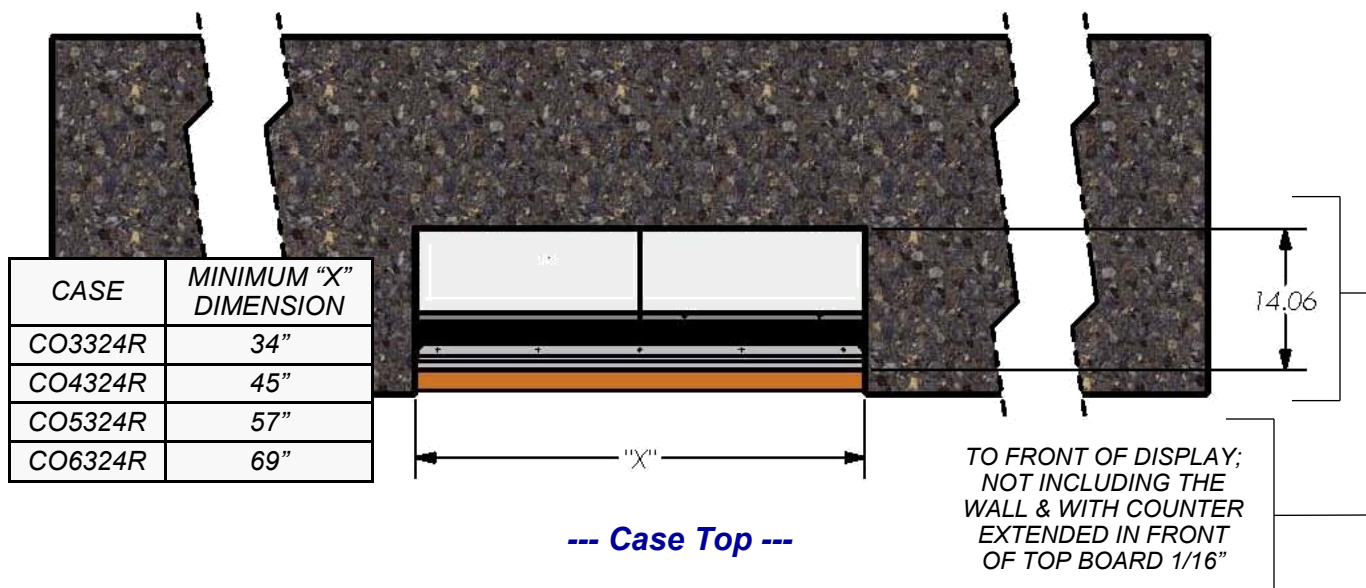

1. Merchandiser Start-Up

- Do not use an extension cord with this appliance.
- Do not operate this equipment with a damaged cord, plug or outlet.
- Insure that the main power switch is off.
- Plug cord into a certified 110V electrical outlet with ground.
- Turn main power switch on (see location at rear of case in illustration below)
- Coil fans should turn on.
 - From inside of the case, check for discharge air from front baffle, to confirm that the fans are functioning properly.
- When the case is in a start-up mode or has been idle for a long period of time, unit may require 75 minutes running time to pull-down temperature.
- Turn lights on.
 - Light switch is next to main power switch.
 - The lights should come on at the same time.
- Always maintain front and rear airflow clearance of twelve inches.

- Obstruction or restriction of air can void warranty.
- Thermometer is also at case rear (as shown below), and controls internal case temperature.
- Interior case temperature is to be 35 °F to 41 °F.
- **Note:** Case temperature is determined by case size. Temperature is controlled by a thermostat. If a temperature setting change is required, refer to instructions in **CAREL® CONTROLLER** sections of this manual.

2. Removable, Condenser Coil Filter

- A removable filter prevents impurities (dust, dirt and debris) from entering condenser coil.
- Filter must be removed weekly and cleaned.
- See **GENERAL CLEANING (TO BE PERFORMED BY STORE PERSONNEL) - EXTERIOR** in this operating manual for cleaning instructions.

Removable, Magnetized Condenser Coil Filter (Optional). **Note:** Filter is Placed over Condenser Coil Grille.

Note: Illustration Shown Reflects **REAR ACCESS** Condenser Package. Optional **FRONT ACCESS** Condenser Package Has Similar Electrical Layout.

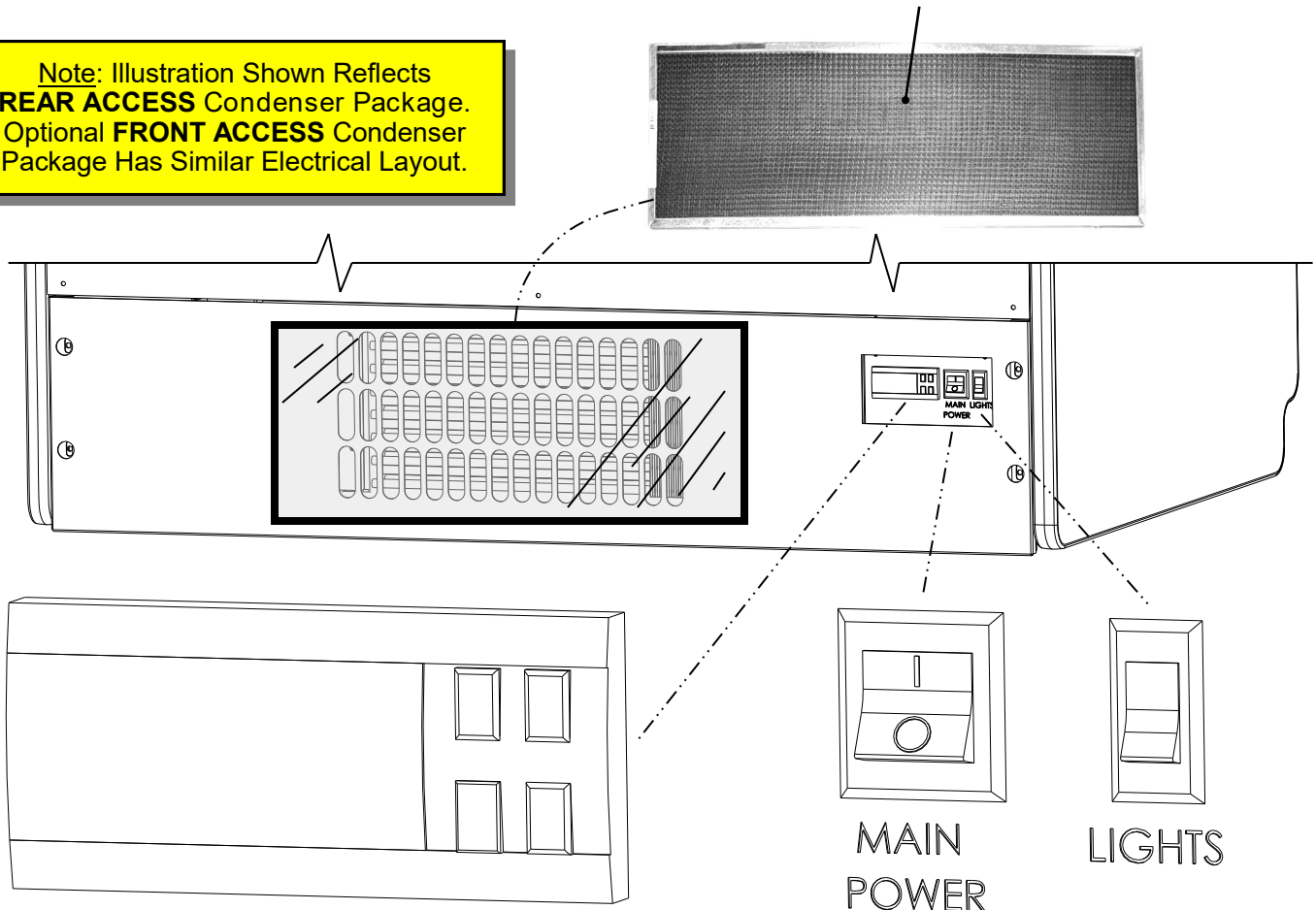

1. Product Placement

- Product can be placed on decking or steps (risers) within self-service display area.
- A wide range of product may be displayed.

2. Honeycomb Airflow Consideration

- Airflow from honeycomb air diffuser is designed to flow over (and around) product to return air grille at case front.
- Caution! You must keep the honeycomb air diffuser unblocked by product for airflow to reach return air grille.
- Caution! You must ALSO keep product OFF return air grill at case front.
- See illustration below.

3. Load Lines

- Load lines represent the maximum height that product can be placed and/or stacked in case.
- Keep product at or under load lines to assure that refrigerated airflow is properly cycled from honeycomb air diffuser through the return air grille.
- Proper product placement will maintain acceptable product temperature.
- See illustration below.

*UPPER LOAD
LINE ORIGIN:
LOWER
EDGE OF
HONEYCOMB
DISCHARGE*

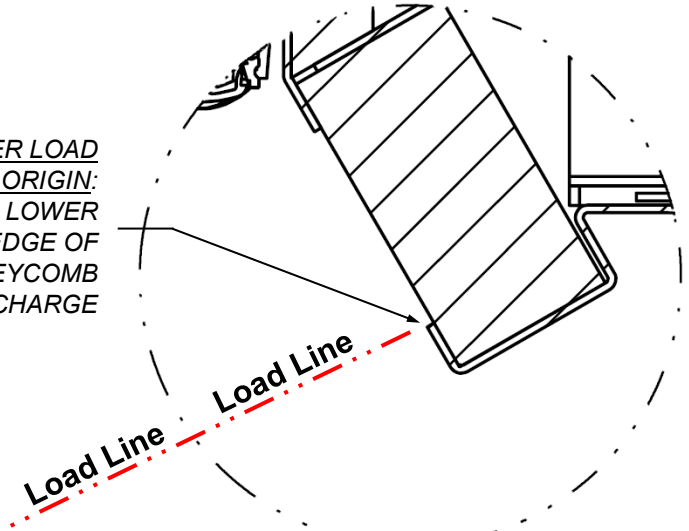

*LOWER LOAD LINE
ORIGIN: FRONT ACRYLIC
AND DECK SURFACE
DIMENSIONAL
INTERSECTION.*

3.66"

4.00"

Return Air Grille Must Not Be Blocked By Product!

Sample Product

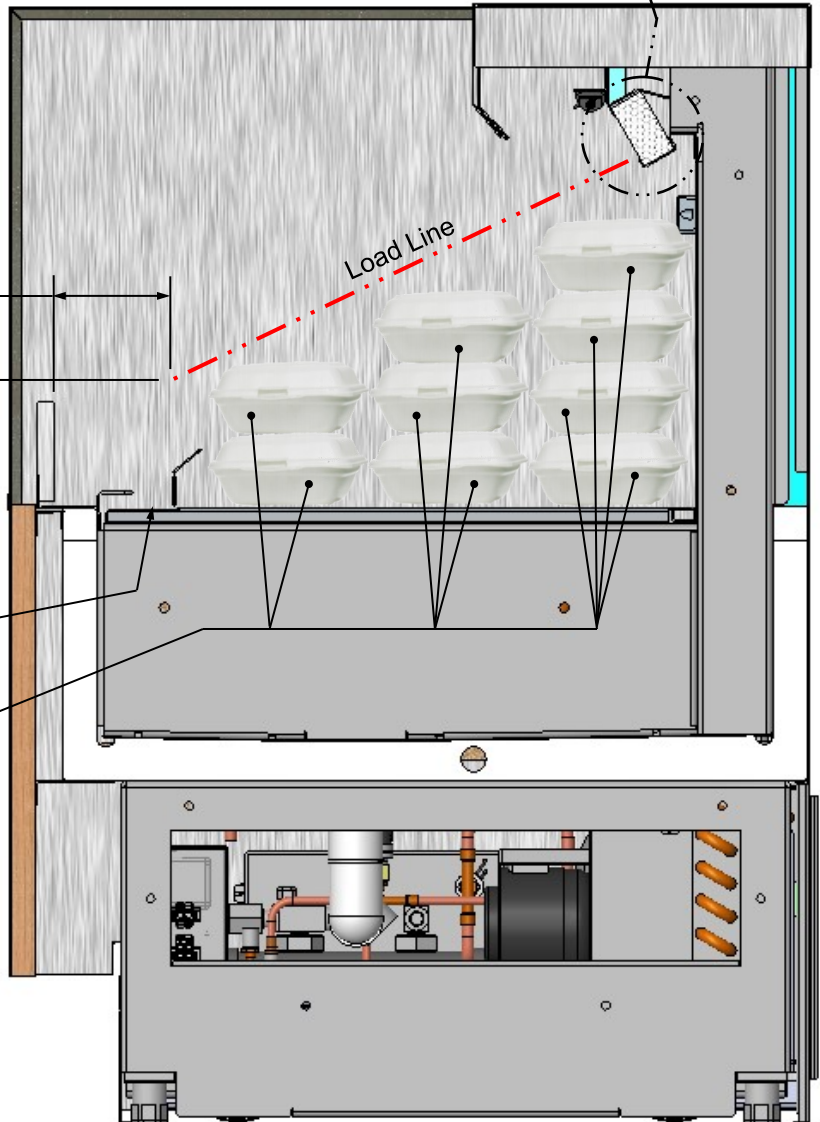

Note: Perspective View of Model CO5324R Is Shown At Right. It May Not Exactly Reflect Every Feature or Option of Your Particular Case.

1. Adjustable Front Toe-Kick (Models CO33R, CO43R, CO53R, CO63R, Etc.)

- Front toe-kick is adjustable.
- Loosen screws holding front toe-kick in place.
- Lower front toe-kick to floor.
- After case is in desired position, use silicone sealant to seal toe-kick to floor.
- See next page for removable front panel (without screws) for models CO3434RG.5716, CO3034RG.5718 and CO3034RG.5718A

2. Light Fixture

LED light fixture is at upper section of case as shown in illustration below.

- LEDs light fixtures rarely require change-out.

Note: Illustrations Shown May Not Exactly Reflect Every Feature or Option of Your Particular Case.

- See **MAINTENANCE - LED LIGHT FIXTURES** section in this manual for more specifics.

3. Night Curtain

Optional night air curtain is near honeycomb.

- See **OPTIONAL NIGHT AIR CURTAIN OPERATING INSTRUCTIONS** section in this manual for more specific illustrations.

4. Honeycomb Air Diffuser

- See **PREVENTIVE MAINTENANCE - HONEYCOMB (BY TRAINED SERVICE PROVIDERS ONLY)** section in this manual for complete information.

5. Thermometer

- Thermometers provide internal air temperature only (not actual food temperature).
- Use probe thermometers to determine actual product temperatures.

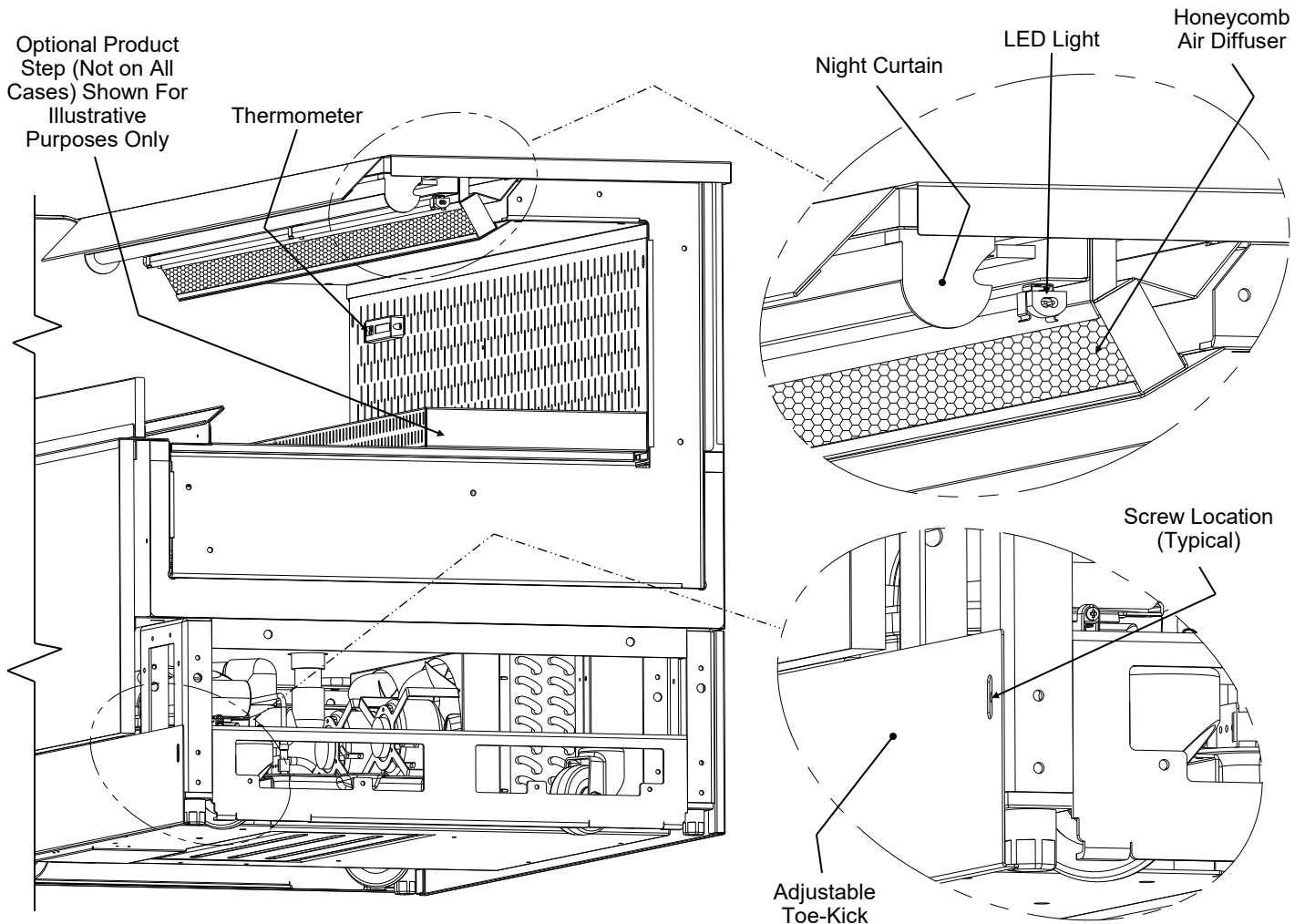

1. Removable Toe-Kicks

- Front toe-kick is removable.
- Simply lift up and off.
- After case is in desired position, use silicone sealant to seal toe-kick to floor.
- See previous page for adjustable front toe-kicks (with screws) on models CO33R, CO43R, CO53R, CO63R, etc.
- See next page for magnetic removable front panels.

2. Product Risers (aka "Steps")

- Risers ("steps") allow product to be more prominently displayed.
- Risers are to rest on decks and be placed as far back as possible (up against rear plenum) as shown in illustration below.
- See **GENERAL CLEANING (TO BE PERFORMED BY STORE PERSONNEL) - INTERIOR** in manual for instructions on cleaning risers/steps.

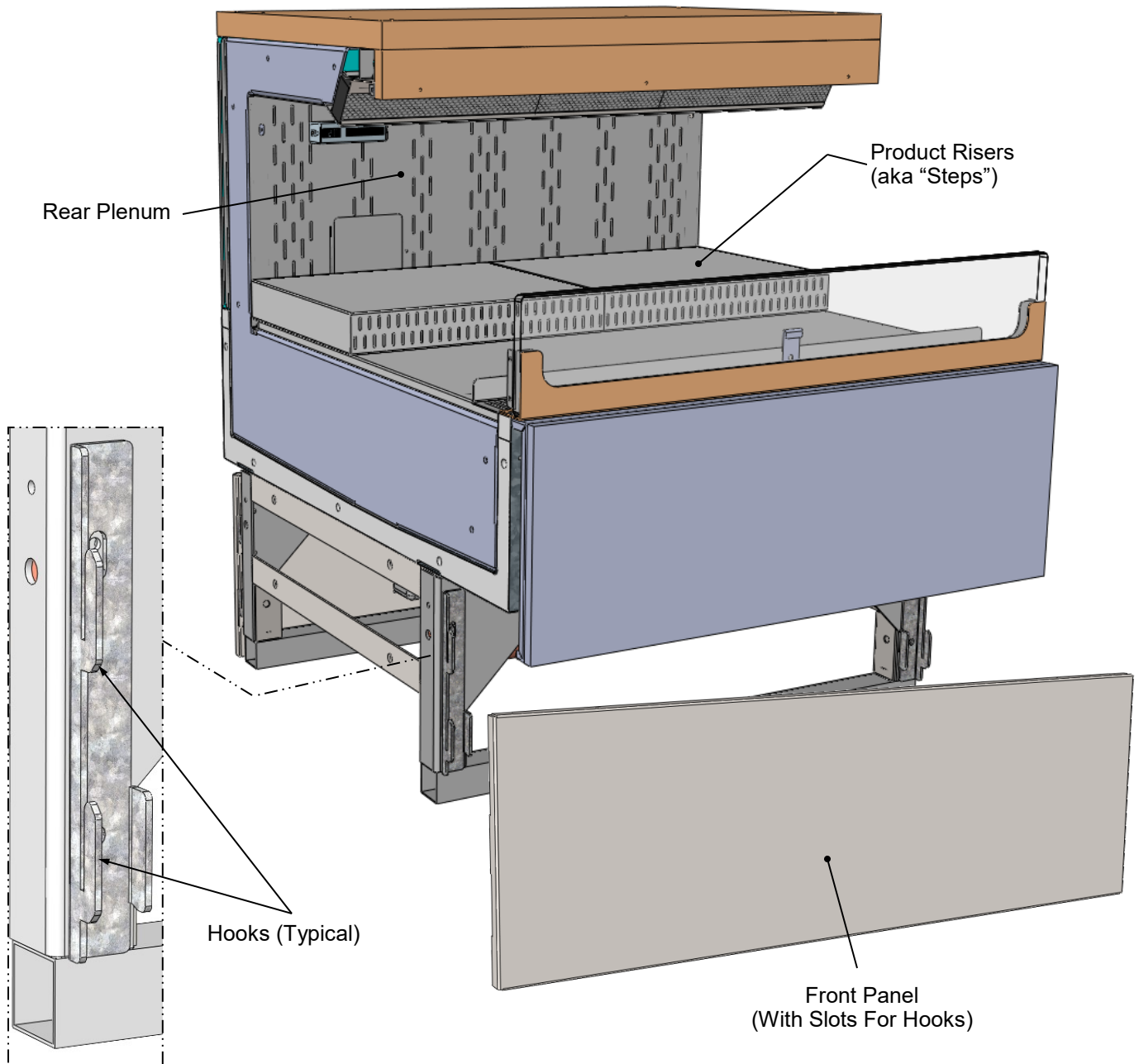

MAINTENANCE - REMOVABLE FRONT TOE-KICKS (MAGNETIC SYSTEM)

Removable Magnetized Front Panels

- These panels are found on models CO3434RG.5716, CO3436RG.5716, CO3034RG.5718 and CO3034RG.5718A
- Toe-kicks are shipped separately.
- Toe-kicks are to be placed on case via slot/magnet attachment method.

- Remove toe-kick by pulling away from lower magnet and lifting up and off hooks.
- No screw removal is required.
- See illustrations below
- See previous page for slot/hook removable front panels.

Note: Illustrations Shown May Not Exactly Reflect Every Feature or Option of Your Particular Case.

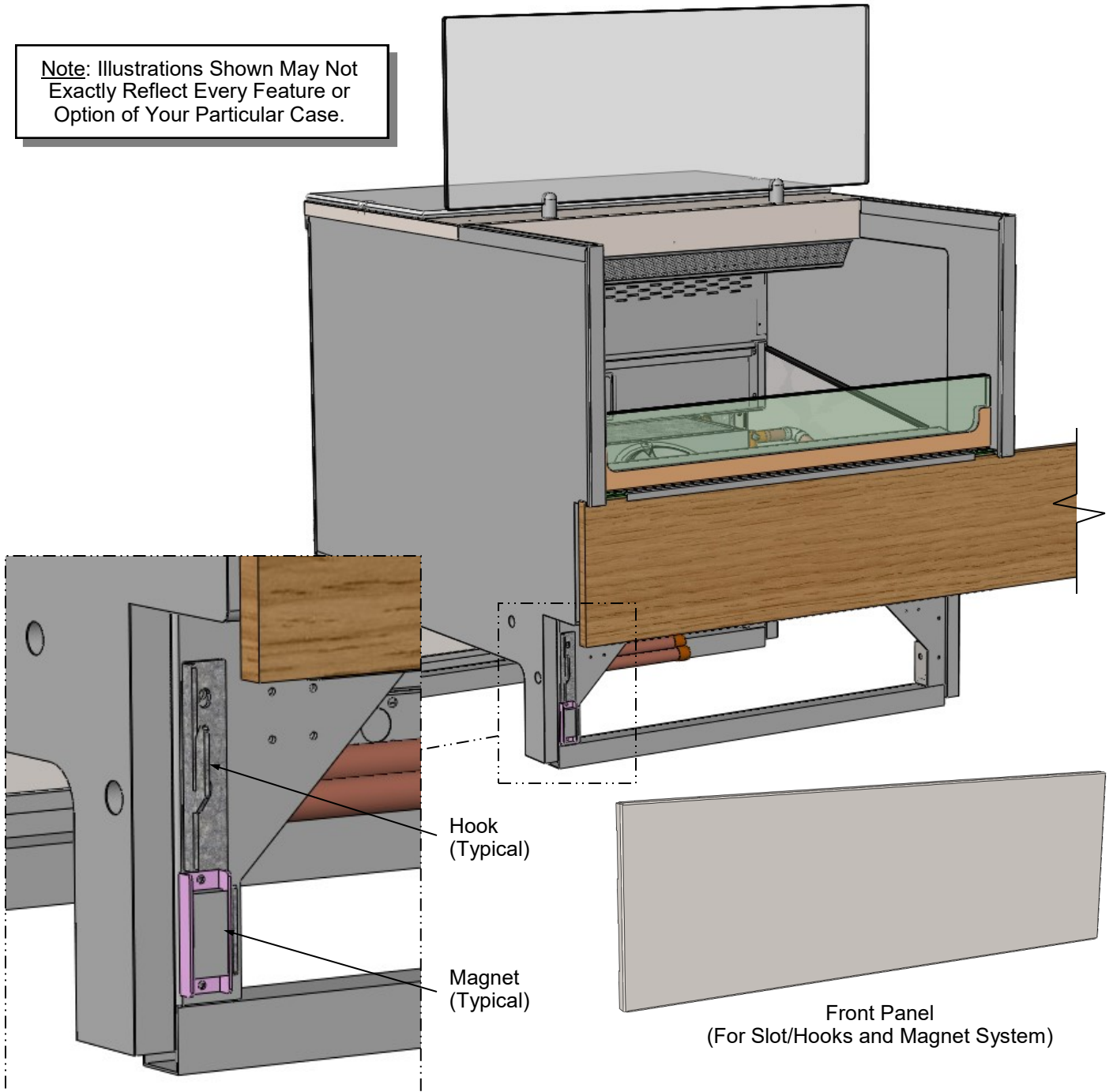

LED Style Light Fixtures

Removal of Faulty LED Lights:

- LED lights rarely require change-out.
- Contact Structural Concepts' Technical Service Department for replacement LED lights.
- Turn off LED light switch.
- To remove faulty LED light, follow these steps:
 - A. Disconnect plug from LED light.
 - B. Using both hands, grasp LED light assembly (with its magnetic mounting clips). Pull downward and off its shelf (or header).
 - C. Remove magnetic mounting clips from LED light by pressing against flange part of clip with thumb.

>> **Note:** Mounting clips **MAY** be riveted to shelf or header. In such instances, simply remove LED light from mounting clips by pressing against flange part of clips with thumb.

Replacement of LED lights:

- Attach magnetic mounting clips onto LED light.
- Adjust magnetic mounting clips so they are equally spaced on LED light.
- Reattach LED light assembly to its shelf/header.
- Position properly in shelf/header.

>> **Note:** If mounting clips are riveted to shelf (or header), attach by placing LED in base of clip and then snapping into clip at **FLANGE SIDE**.

- Press plug's barrel-shaped insert all the way into LED light.
- **Important:** If plug is not inserted **ALL THE WAY IN** the LED light's orifice, the light may not energize. See **"BAD"** vs. **"GOOD"** insertion illustrations below-right.
- Turn LED light switch back on.

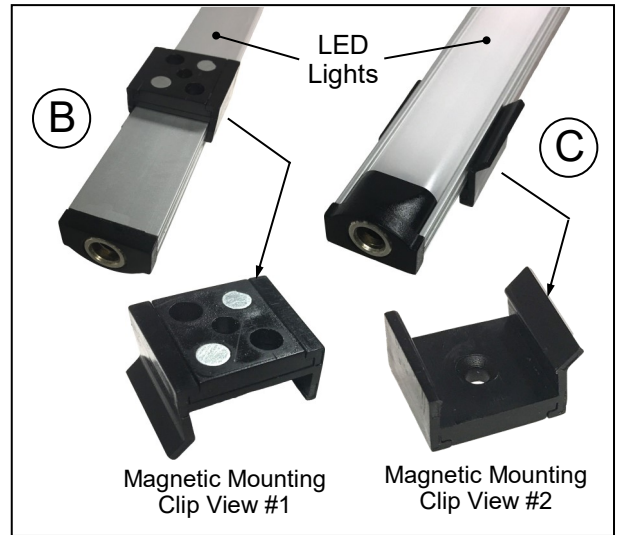
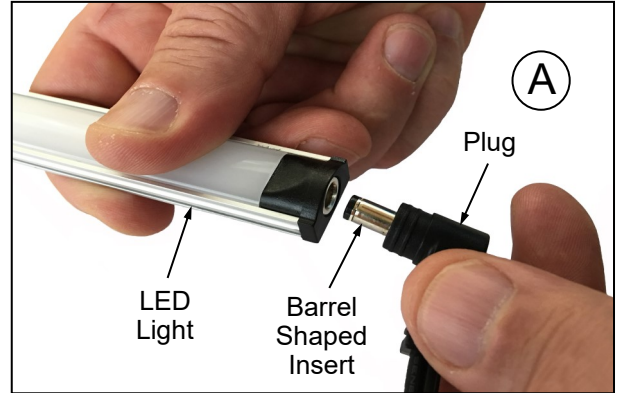

Note: Illustrations Shown May Not Exactly Reflect Every Feature or Option of Your Particular Case.

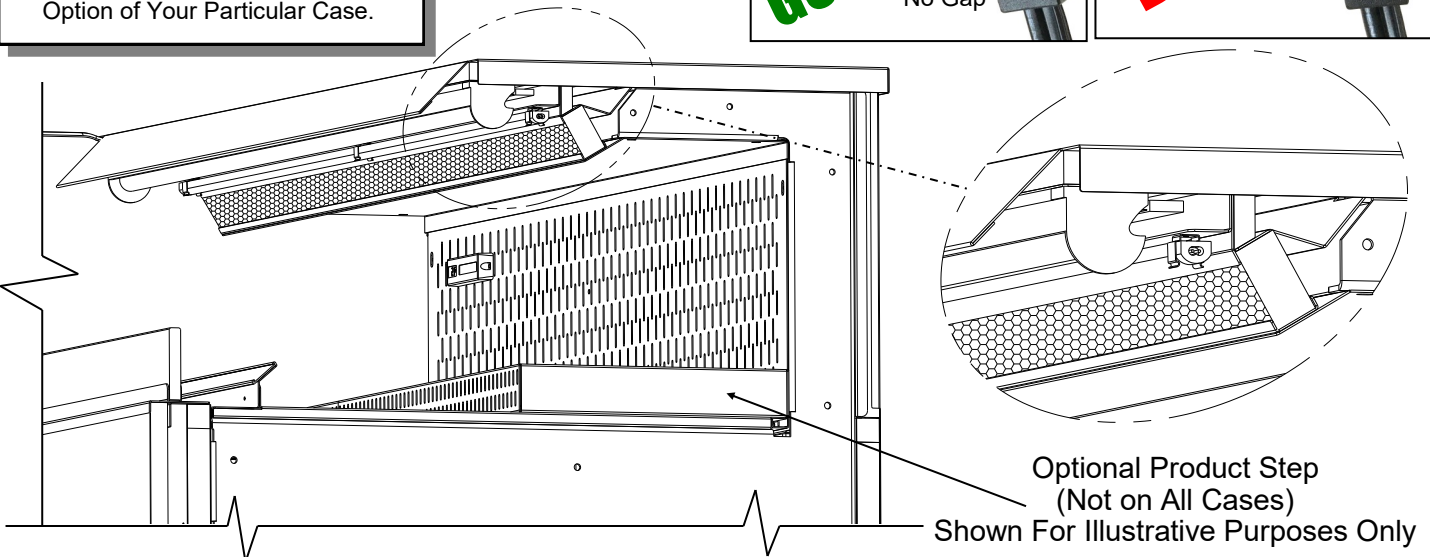

Night Air Curtain Installation & Operating Instructions

1. Use caution when handling night air curtain.
2. Display case may come with night curtain already attached. If not, a retrofit kit will be provided. If using SCC-supplied retrofit kit, attach to display case by centering night curtain along top-front of case as shown in illustration below. Attachment magnets will hold night air curtain firmly in place.
3. Grasp the handle and pull downward to desired location in front of case (as shown in illustration below).
4. To return night air curtain to its retracted position, grasp handle, lift up and away from its magnetic attachment and carefully wind night air curtain back into roll.
5. **Caution!** Do not allow spring-loaded night air curtain to freely snap back into roll. Doing so can eventually destroy night air curtain's tension and retractability.
6. To entirely detach night air curtain from case, simply pull it downward and away from case. Caution! Do NOT drag night air curtain along top (underside) of case or magnets may scratch or mar surface. Simply lift night air curtain downward and away from case. Store in safe place away from foot-traffic.
7. Store in a safe and secure space until needed again.

NOTE: THE BELOW ILLUSTRATION MAY NOT EXACTLY REFLECT EVERY PARTICULAR CASE'S FEATURES OR OPTIONS.

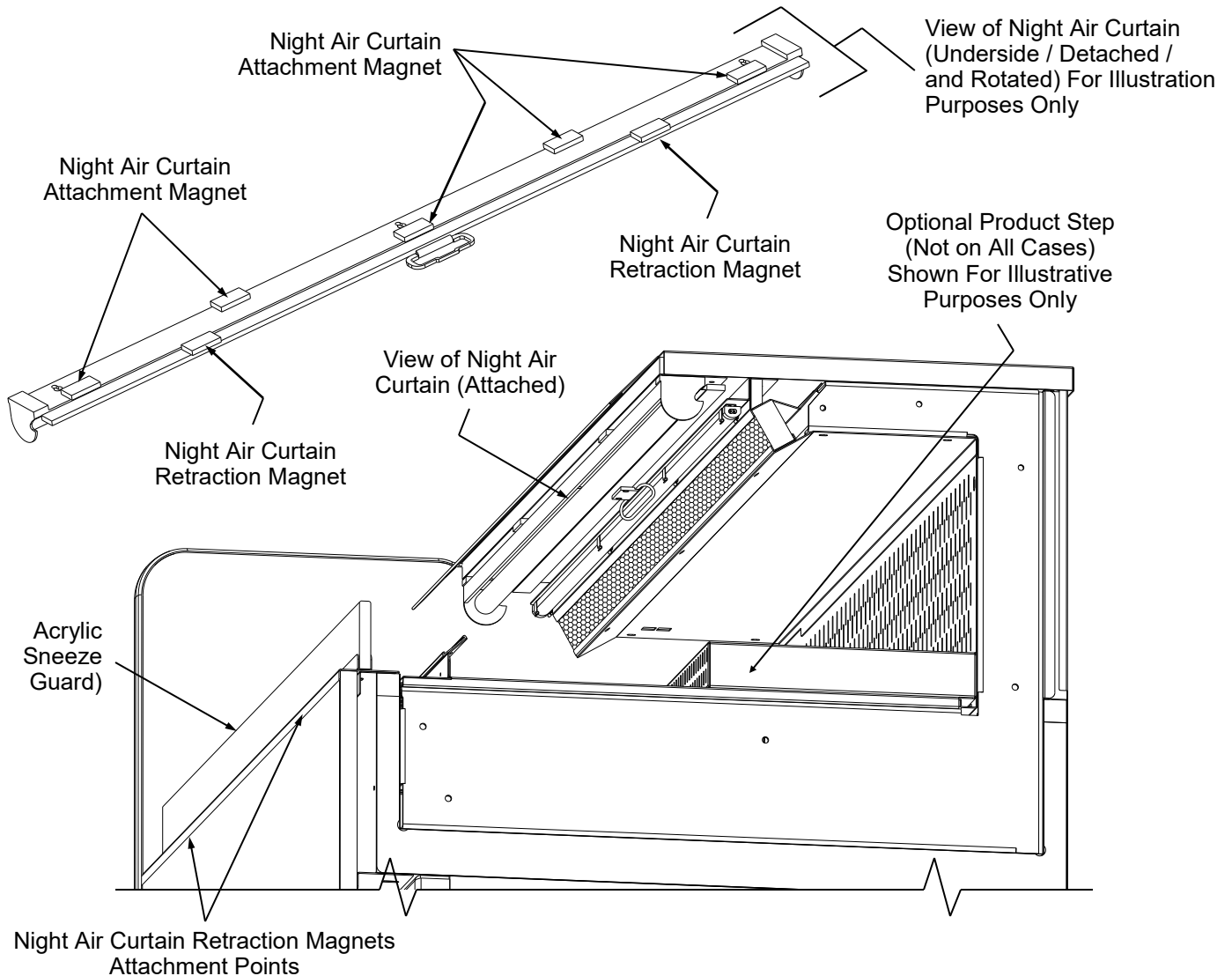

Electrical: Access and Components

Warning, disconnect power before providing maintenance and service to unit.

1. Ballast Access

- A 6 1/2" space is provided at case rear to access electrical components (between refrigeration package and temperature controller plate).
- Electrical components such as terminal block, contactor, and ballast are in main electrical box.

2. Temperature & Defrost Control

- The case temperature is set at the factory, as determined by the case size. The temperature is controlled by a thermostat. If a temperature setting change is required, follow the instructions in the Temperature Controller section of manual.
- If service is required to the temperature control unit, call Structural Concepts. This maintenance should be performed by a certified technician.

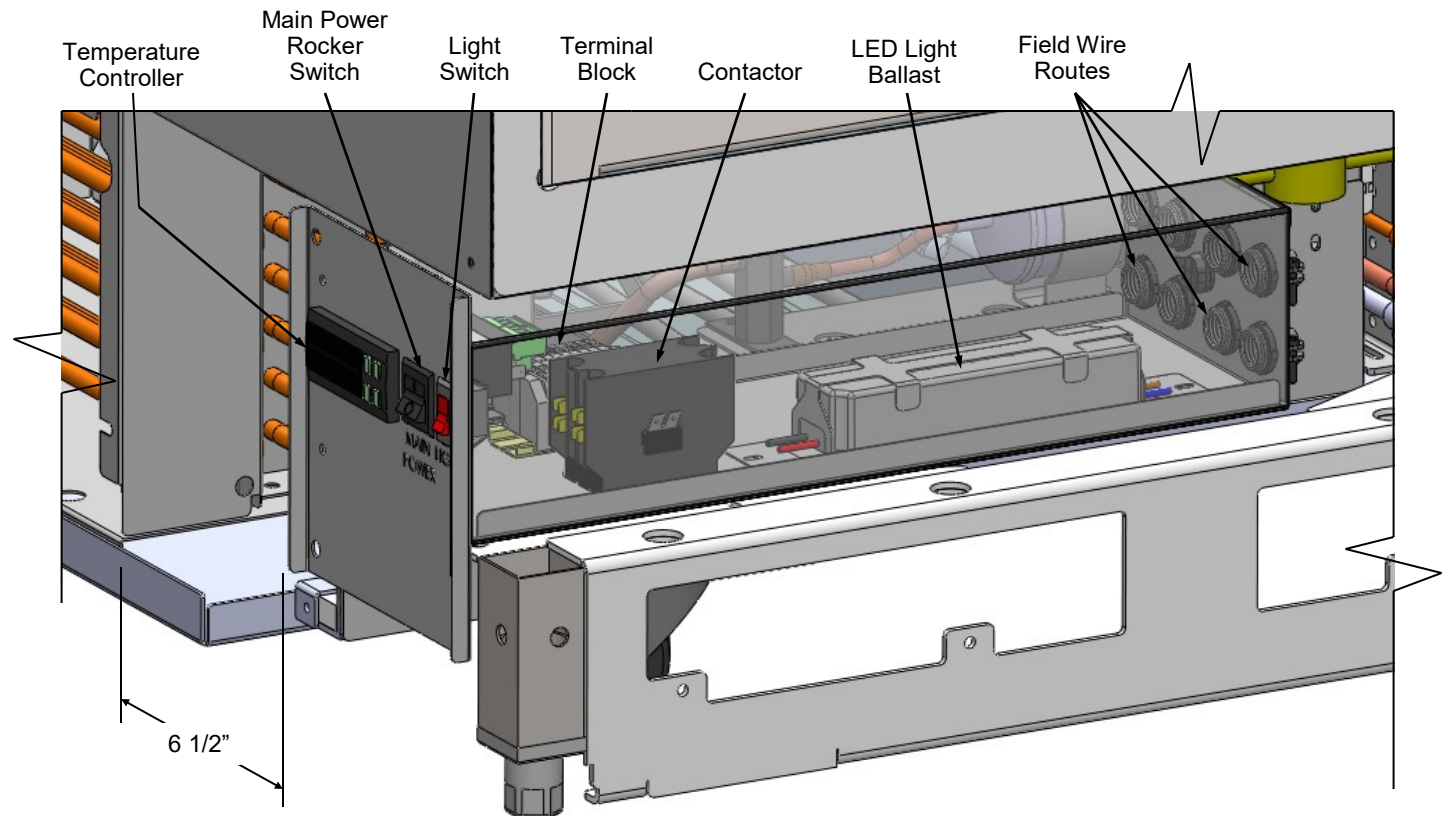

Note: Above Illustration Reflects **REAR ACCESS** Condenser Package. Optional **FRONT ACCESS** Condenser Package Has Similar Electrical Layout.

MAINTENANCE - REAR COMPONENT LAYOUT (MODEL CO3436RG.5716 ONLY)

1. Vertical Glass Divider / Sneeze Guard

- Vertical glass divider/sneeze guard is held securely with mounts. **DO NOT** lean against or strike glass or it could snap off mounts or break.

2. Removable 18" Sanalite® Wrapping Board

- Sanalite® wrapping board is at case rear.

3. Salad Tissue Box Holder

- Salad tissue box holder is at rear-right.

4. Sandwich Wrap Holder

- Sandwich wrap holder is at rear-center.

5. Removable Writing Instrument Cup

- Pens and markers are used for writing on wrapped products.
- **Note:** Writing instruments are to be wiped off with sanitary wipes **AFTER EACH USE**.

6. Removable Sanitary Wipe Bucket

- Sanitary wipes are designed to wipe off writing instruments after each use.

7. Removable Rear Panel

- Rear panel is removable for cleaning purposes.
- Simply remove six (6) Phillips® screws.
- Carefully lift off case rear.

> Removable Holders (From Rear Panel)

- Salad tissue box holder and sandwich wrap holders can be lifted up and off case rear for cleaning purposes. See illustrations below.

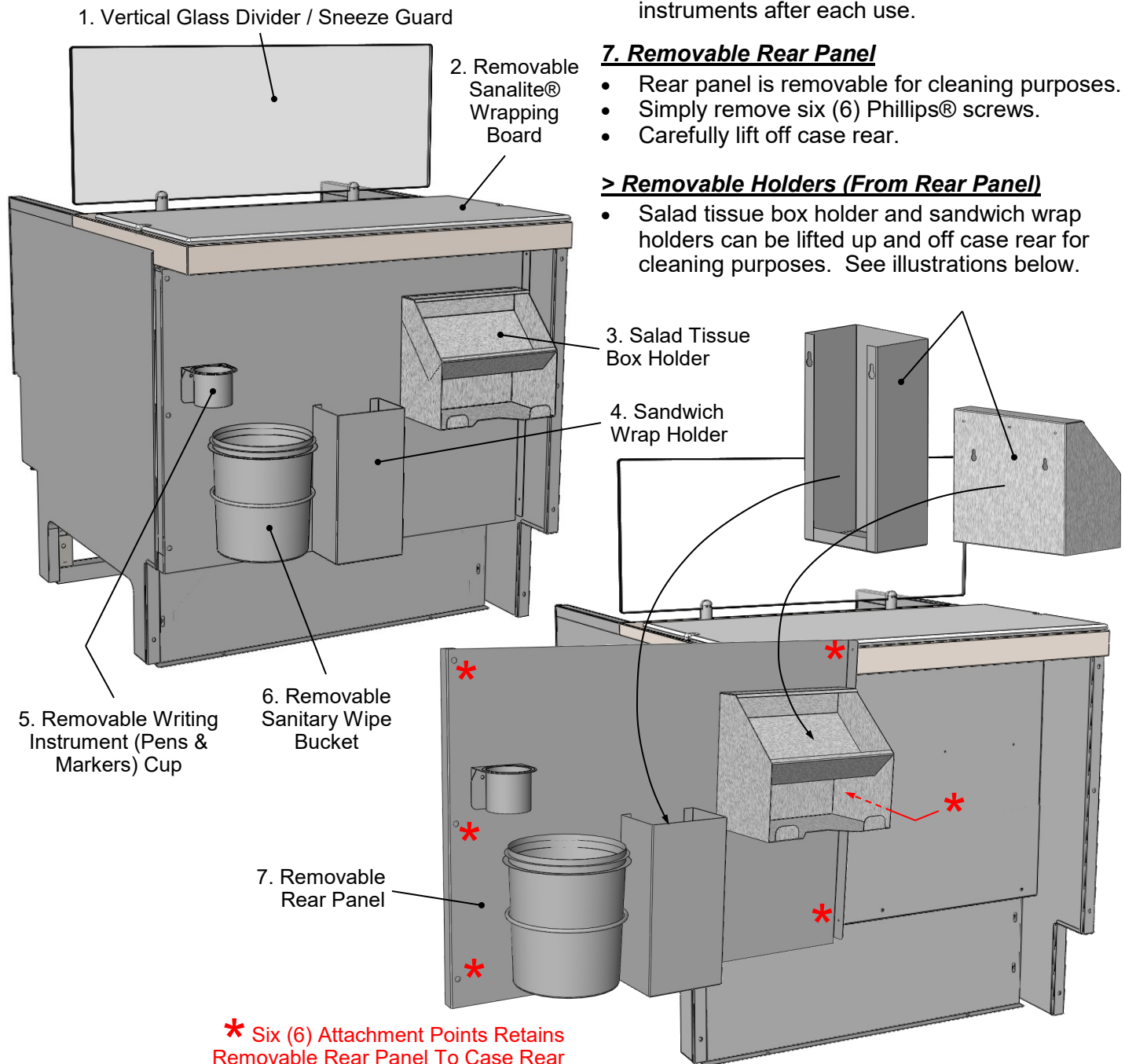

1. Security Covers (Optional) - Models COXXRM

- Security covers are designed to prevent access to merchandiser.
- Security cover is to be placed **OVER** upper latch retaining clip and **UNDER** lower latch retaining clip.
- Lift security cover up and off with handles.

2. Locking Mechanism

- Locking mechanism key allows plate cam lock to be rotated under upper retaining clip.
- Proper rotation of plate cam lock prevents cover from being removed.

3. Key Storage / Cover Storage

- When security cover is attached to case, remove keys and store in easy-to-remember, yet secure location.
- When security cover is removed from case, store in safe, secure location away from foot traffic.

4. Rear Flip-Down Hinged Door (Optional)

- Certain models have a rear, flip-down hinged door with perforated panel (to maintain proper airflow).
- Handle is to be pulled outward to open door.
- **Caution! Hold door securely while lowering it against hinges.**
- **If door is allowed to fall downward onto its own weight, it can damage hinges.**
- Models include CO43R-FS as well as others.
- See illustration below.

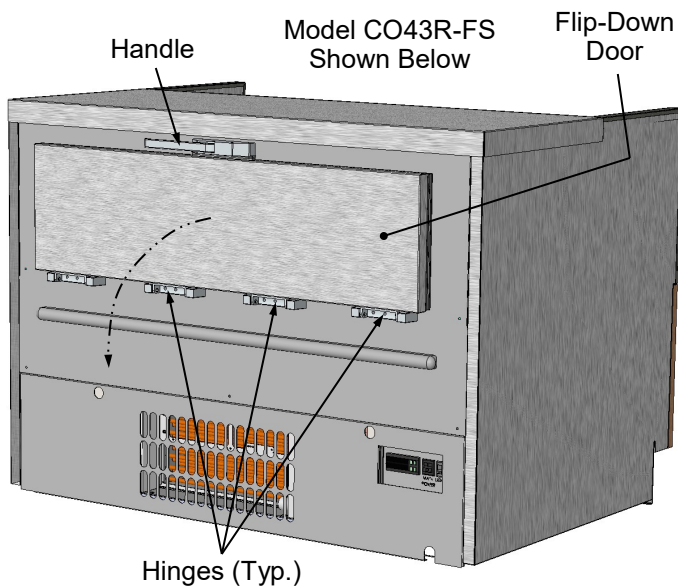
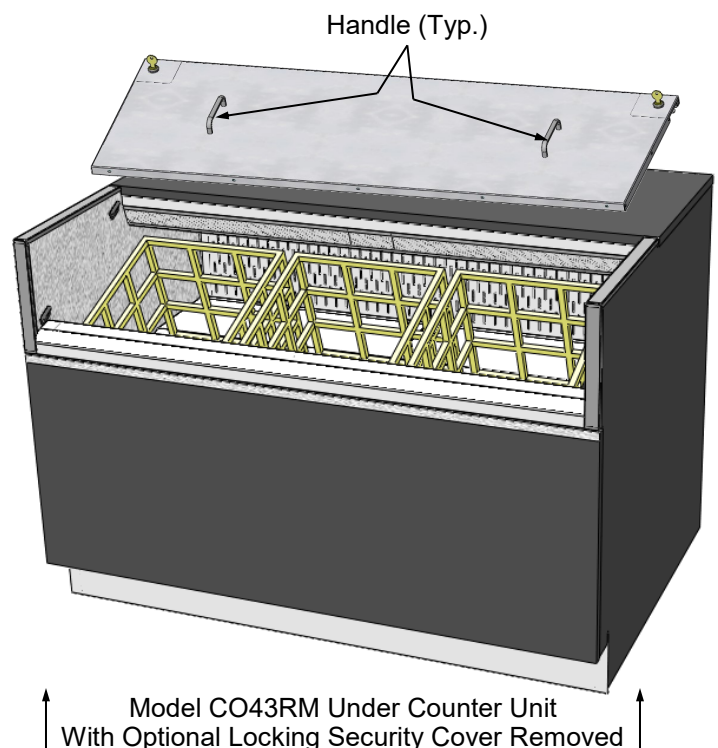
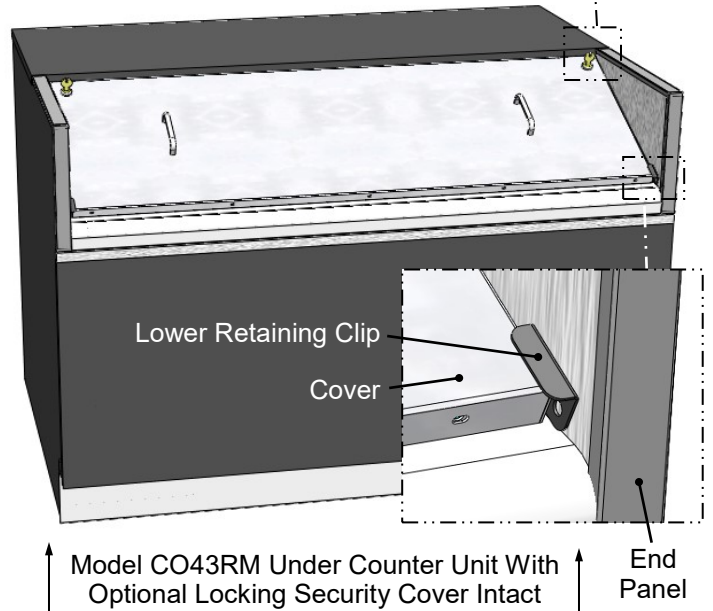
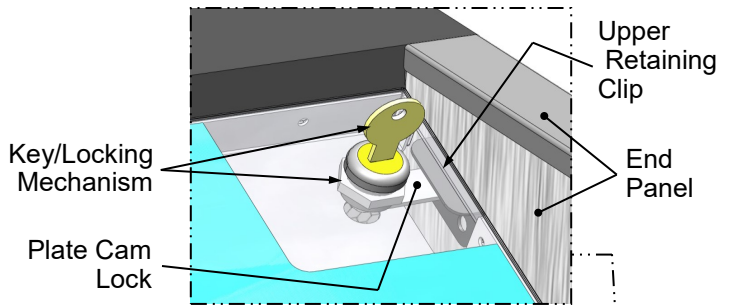

1. Merchandiser Overview

- Model CO4836R.5716 and CO4836RG.5716 also have a bread display unit that sits atop counter and is protected by a glass sneeze guard. This bread display unit is also separately manufactured by SCC as Model BDXXXX.
- Stainless steel posts hold sneeze guards in position.
- Sneeze guards are glass (sides and top).
- Acrylic bread bins and bread display supports are removable.
- Stainless steel brackets suspend bread display.

- Stainless steel removable wrap cubbies are accessible at case rear.
- See illustration below.

2. Rear Panel Removal (For Cleaning Purposes)

- See **MAINTENANCE - REAR COMPONENT LAYOUT (MODEL CO3436RG.5716 ONLY)** section in this manual for location of the six (6) rear panel attachment points.
- Removing screws at these attachment points will allow entire rear panel to be removed from case.

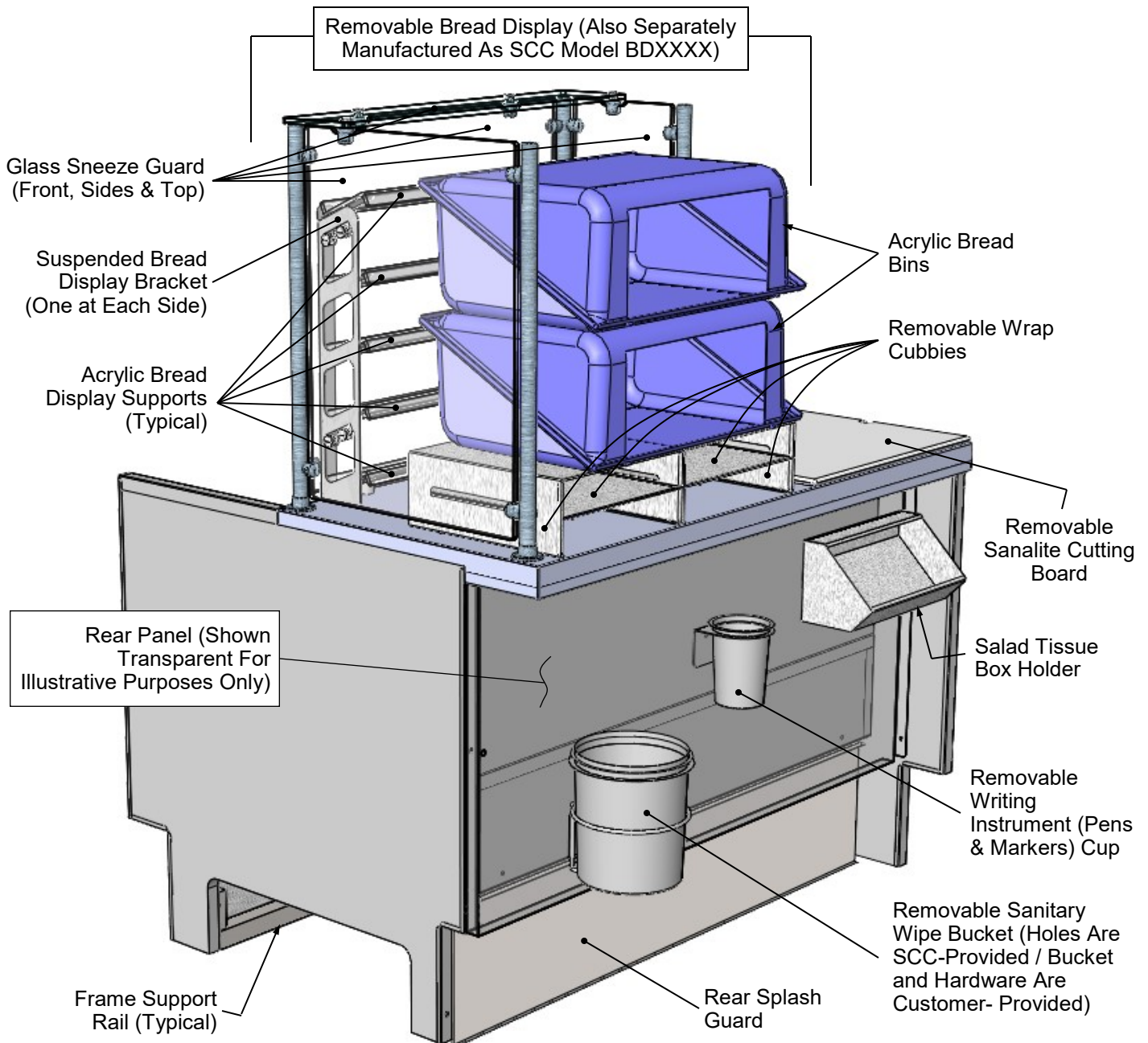

1. Evaporator Fan Access

- Remove lower decking.
- Lift decks straight up and out to avoid scratching insides of case while removing decks.

2. Thermostatic Expansion Valve Access

- TXV also becomes accessible upon removal of decking.

3. Drain

- Drain is located at center of tub (under evap. fan).
- Access to drain may also be gained by removing evaporator fan shroud.

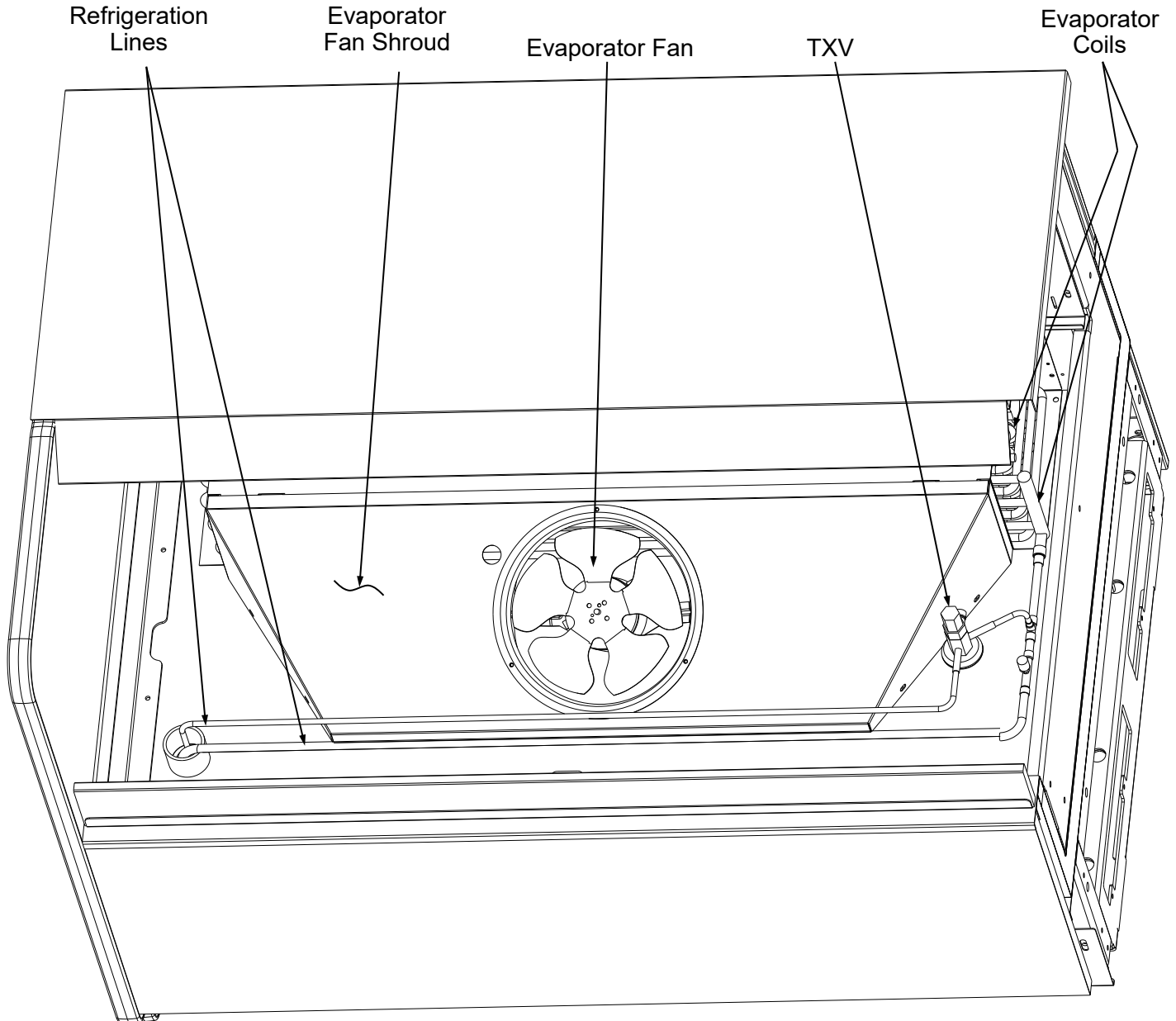

Above Illustration Shown With End Panel and Decking Removed For Illustrative Purposes

REFRIGERATION - EVAPORATOR AREA: MODELS CO43RM / CO63RM (AND SIMILAR UNITS)

1. Evaporator Fan Access

- Remove milk crates and lower decking.
- Lift decks straight up and out to avoid scratching insides of case while removing decks.

2. Thermostatic Expansion Valve Access

- TXV is accessible upon removal of decking.
- See illustration below.

3. Drain

- Drain is located at center of tub (under TXV).
- Access trough by removing evaporator fan shroud.

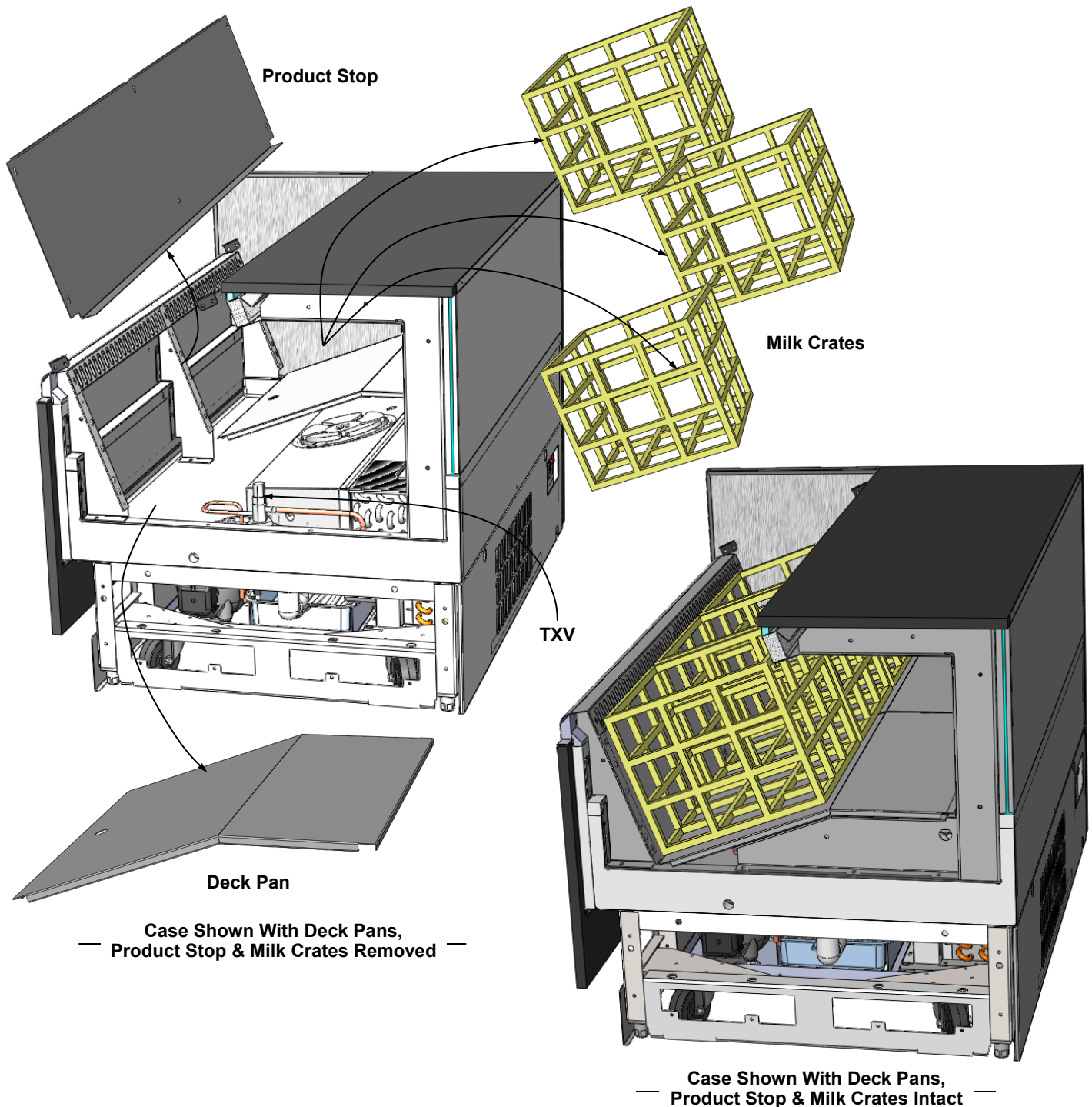

1. Evaporator Fan Access

- Remove lower decking.
- Lift decks straight up and out to avoid scratching insides of case while removing decks.

2. Balancing Valve / Sweat Valve Access

- Balancing valve and sweat valve becomes accessible upon removal of decking.

3. Drain

- Drain is located at front right side of as shown below.
- Access to drain may also be gained by removing evaporator fan shroud.

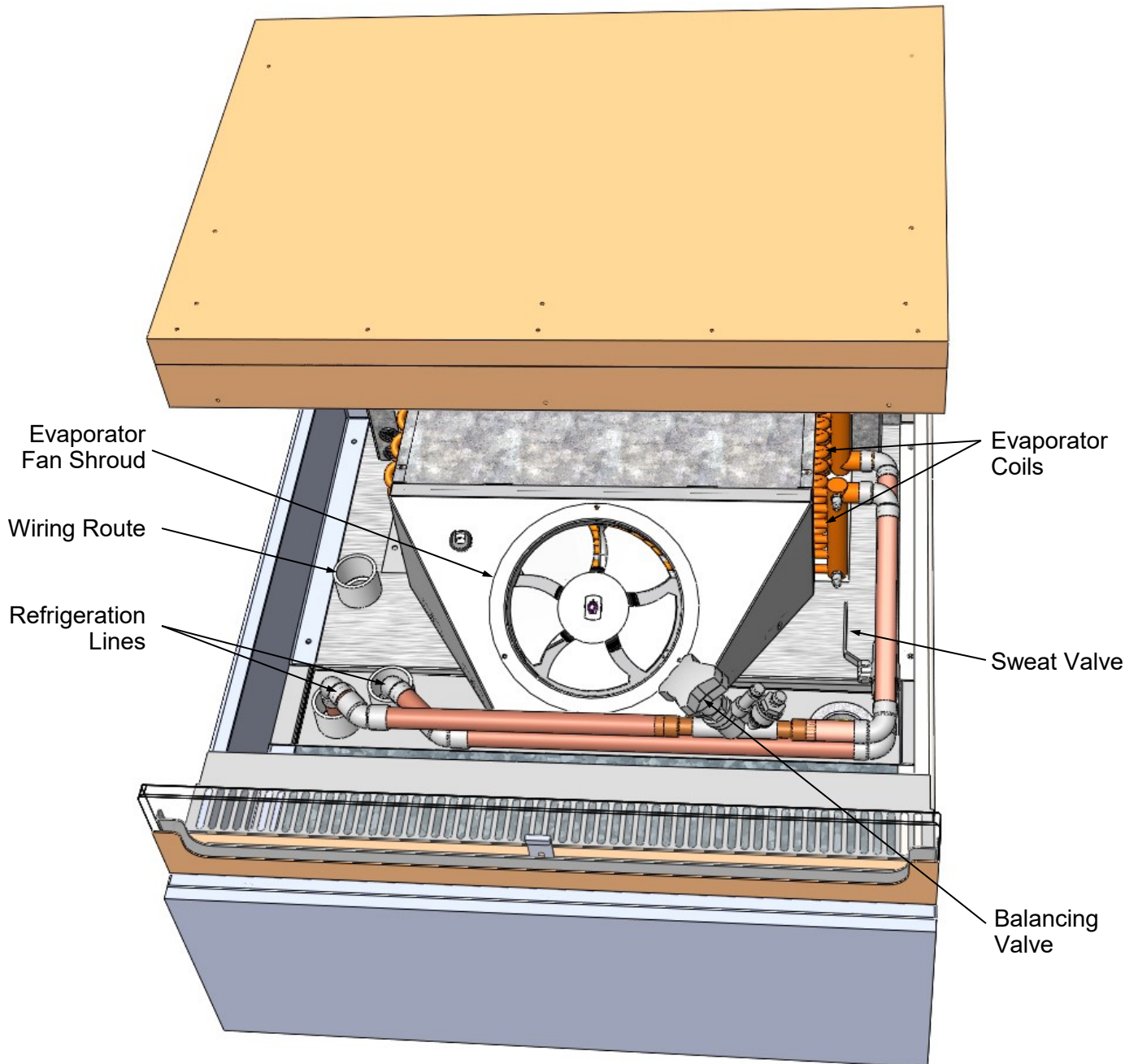

Above Illustration Shown With End Panel and Decking Removed For Illustrative Purposes

REFRIGERATION - CONDENSATE PACKAGE ACCESS (SCREW REMOVAL REQUIRED)

Refrigeration Fundamentals

1. Condensate Package Access With Screw Removal Required

- ***Assembly or disassembly and servicing of condensate package is to be accomplished by a licensed refrigeration contractor.***
- Refer to maintenance fundamentals for access.
- Remove rear grille (by removing 4 screws) as shown in illustration at right and below.
- See next page for units with rear grilles requiring NO screw removal.

View of Case Prior To
Rear Grille Removal

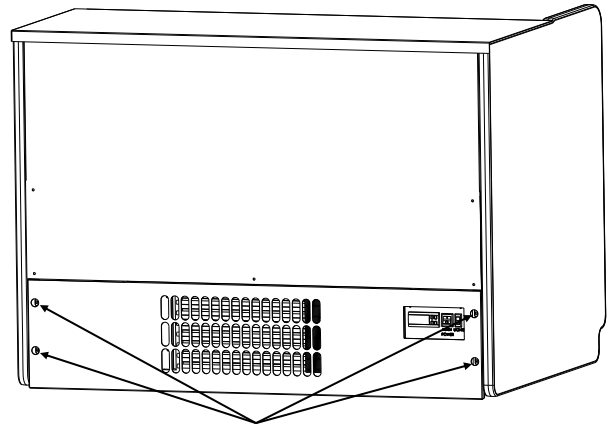

Screw Removal Required
To Remove Rear Grille

Note: Illustrations Shown May Not Exactly Reflect Every Feature or Option of Your Particular Case.

View of Case
Rear After Rear
Grille Removal

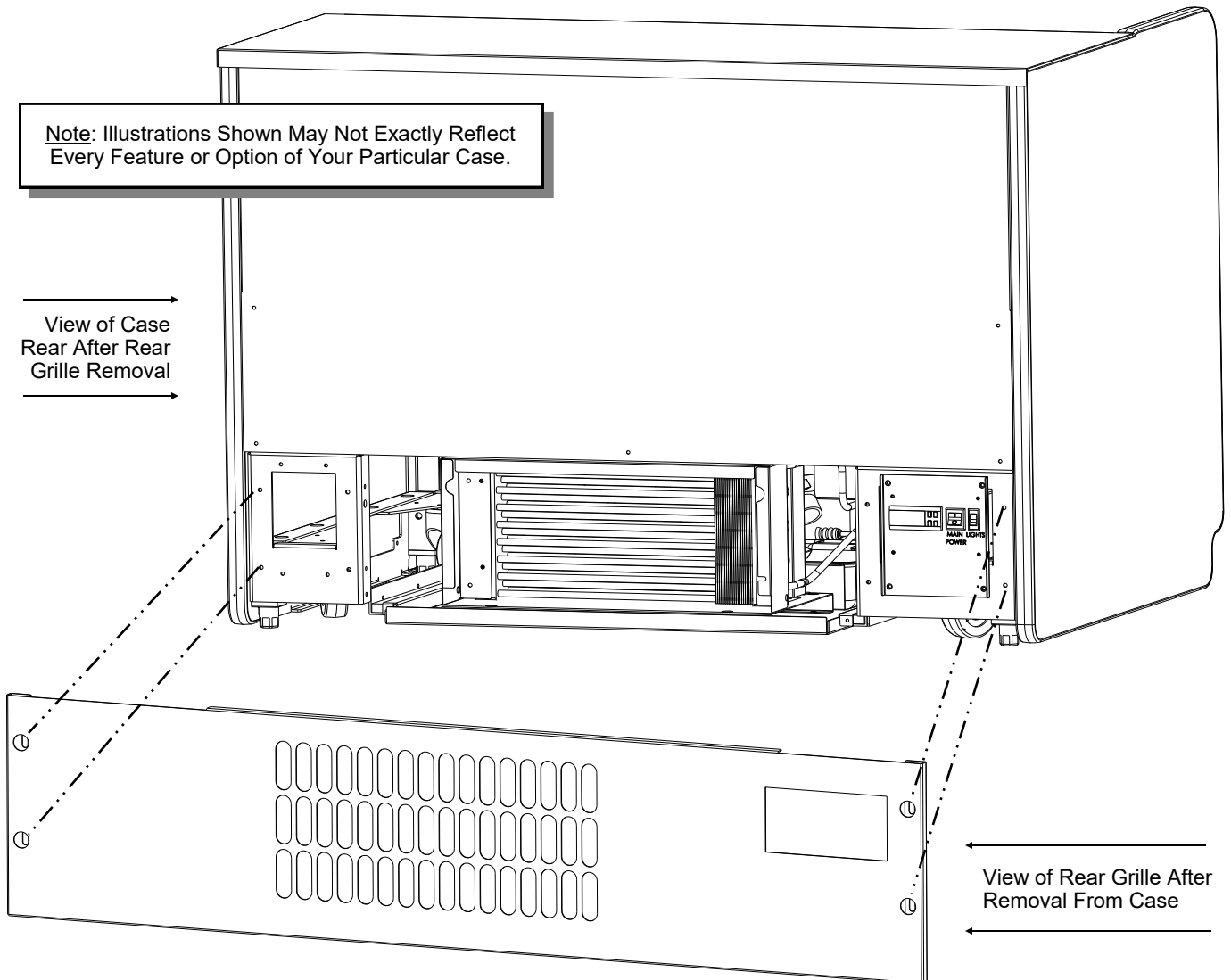

View of Rear Grille After
Removal From Case

REFRIGERATION - REAR CONDENSATE PACKAGE ACCESS (NO SCREW REMOVAL REQUIRED)

Refrigeration Fundamentals, Continued

2. Rear Condensate Package Access - No Screw Removal Required

- **Assembly or disassembly and servicing of condensate package is to be accomplished by a licensed refrigeration contractor.**
- Remove rear grille by grasping two (2) finger holes and pulling outward.

- Rear grille will then be free from rear panel magnets (one at each end).
- Slots of rear grille (one at each end) grille may then be lifted up and off rear panel hooks (one at each end).
- See previous page for rear grilles that require screw removal.

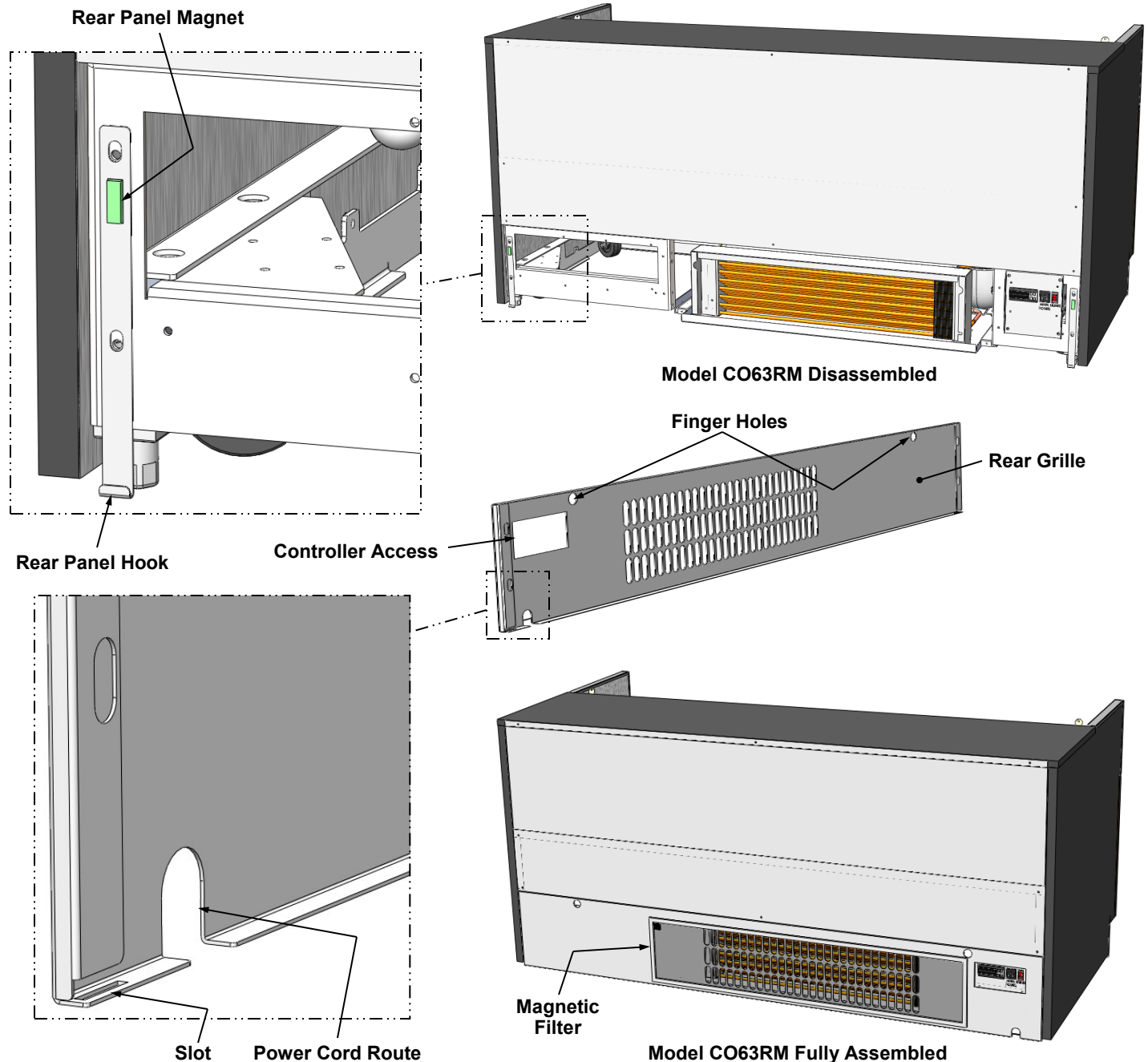

REFRIGERATION - FRONT CONDENSATE PACKAGE ACCESS (NO SCREW REMOVAL REQUIRED)

Refrigeration Fundamentals, Continued

3. Front Condensate Package Access - No Screw Removal Required

- **Assembly or disassembly and servicing of condensate package is to be accomplished by a licensed refrigeration contractor.**

1. View of fully attached front panel and toe-kick/front grille. Note: Model CO3324R.7654 is shown for illustrative purposes only; your model may vary.

2A. Upper front panel bracket (for top of front panel to be placed).

2B. Lower front panel's slot (that rests on hooks at both ends of case).

2C. View of hook that lower front panel rests on (typ.).

3A. Toe kick/front grille shown removed from case.

3B. View of magnets that toe-kick/front grille attaches to. Note: Magnets are at both ends of case.

4. If shipment damage-prevention screws are intact, they must be removed to slide condenser package out from under case.

5. Carefully slide condenser package pan out from under case to access various components.

>> Return all components to case in reverse order they were removed.

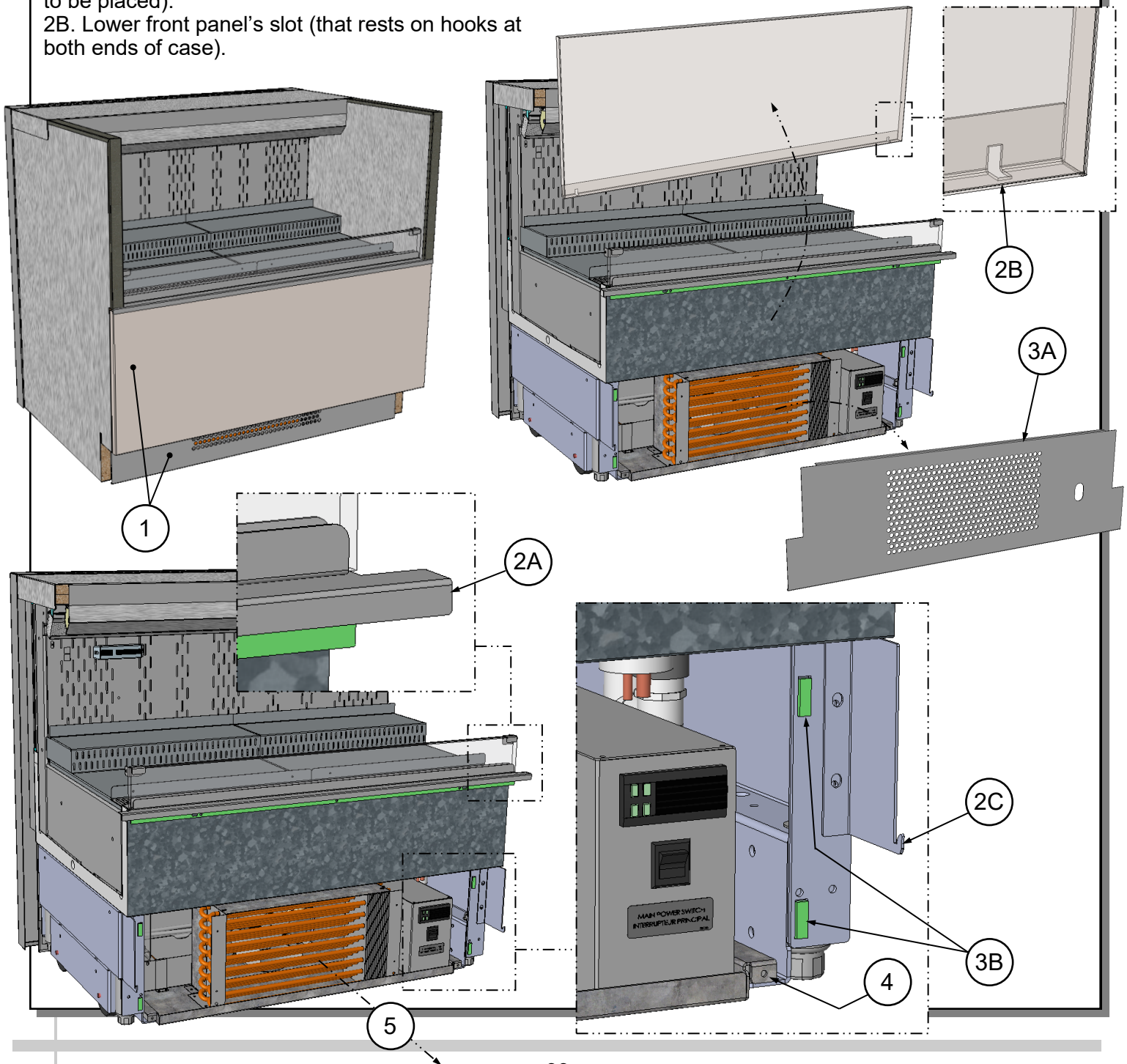

Refrigeration Fundamentals, Continued

4. Condensate Package Illustrated Parts Breakdown

- **Assembly or disassembly and servicing to be accomplished by licensed refrigeration contractor.**
- After rear grille has been removed, slide condensate package out slowly and carefully.
- After service, slide back under case. Return rear grille to case and attach with four (4) retaining screws.
- See previous page for screw removal illustration.

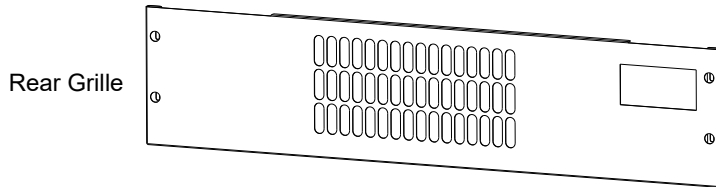
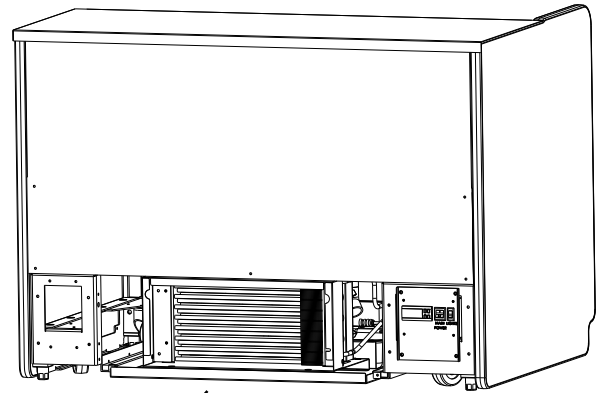

Note: Condensate Package Is Shown Rotated For Illustrative Purposes

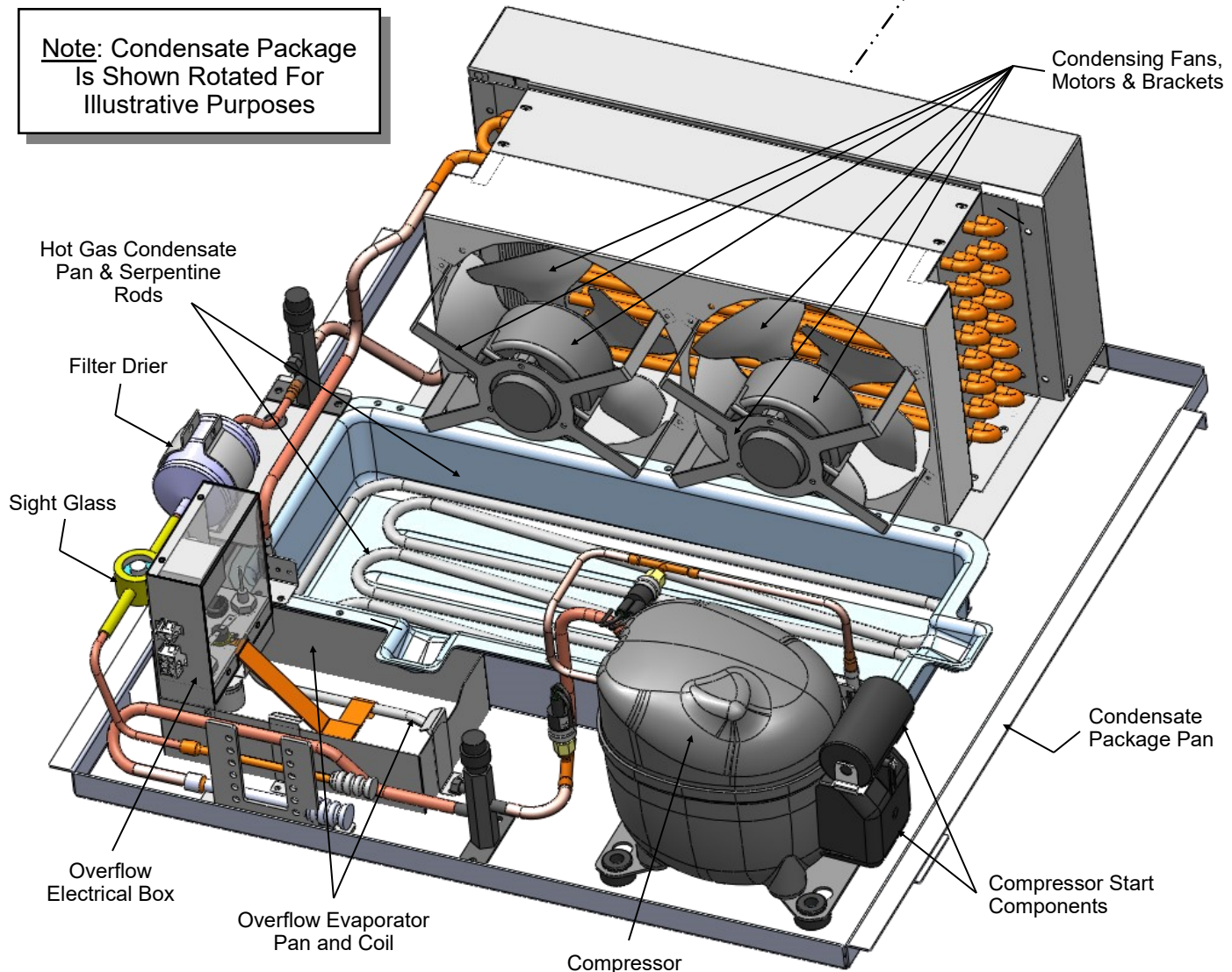

Refrigeration Fundamentals, Continued

5. Condensate Package Illustrated Parts Breakdown

- **Assembly or disassembly and servicing to be accomplished by licensed refrigeration contractor.**
- After rear grille has been removed, slide condensate package out slowly and carefully.
- After service, slide back under case. Return rear grille to case and attach with four (4) retaining screws.

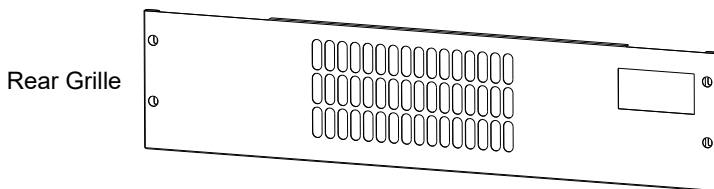
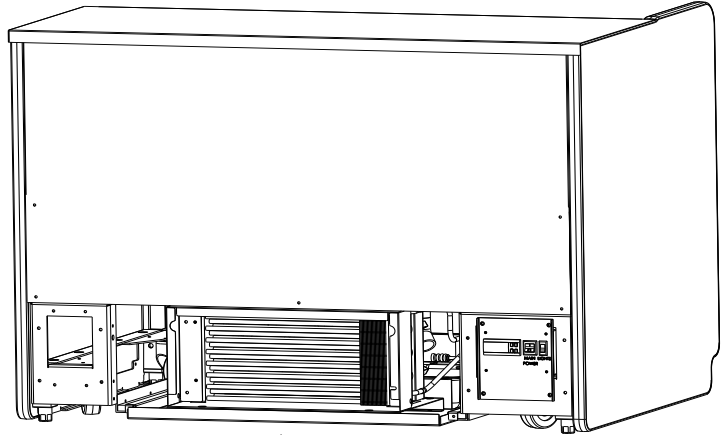

Note: Condensate Package Shown Rotated For Illustrative Purposes

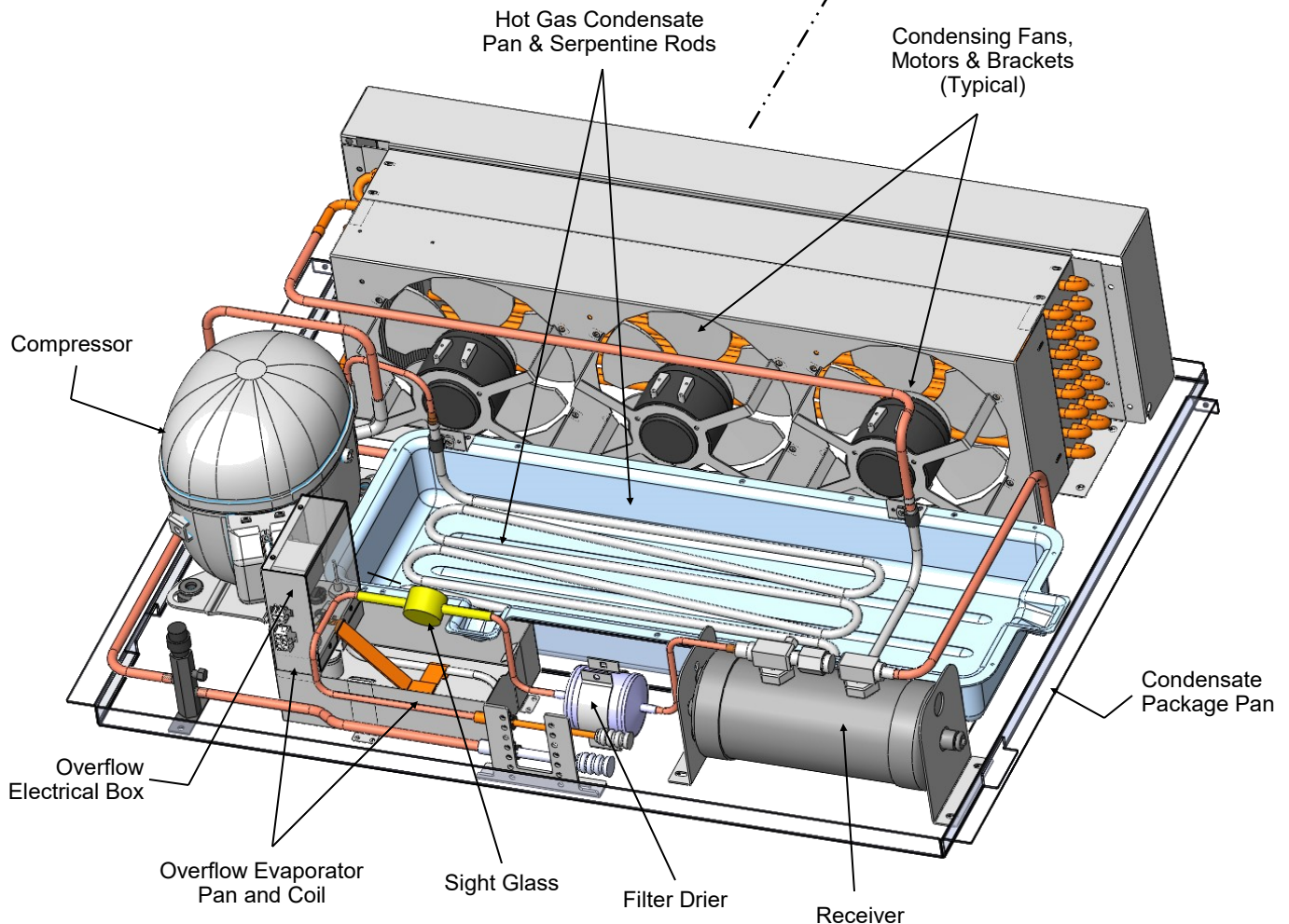

GENERAL CLEANING (TO BE PERFORMED BY STORE PERSONNEL) - EXTERIOR

NOTE: INSTRUCTIONS ARE FOR CASE EXTERIOR ONLY (D=DAILY / W = WEEKLY / M = MONTHLY)

FREQ.	INSTRUCTIONS
D	<u>Sides/Top/Front Panel:</u> Clean with household or commercial cleaner, soft cloth or paper towel.
D	<u>Acrylic Air Deflector:</u> Clean with a mild soap and water solution and a soft cloth.
D	<u>Glass Sneeze Guards:</u> Clean with household or commercial glass cleaner.
D	<u>Sanalite® Cutting Board (Model CO3434RG.5716, CO4836R.5716):</u> Sanalite® cutting boards require very little maintenance. Use a clean cloth to thoroughly wipe entire Sanalite® surface with hot water and soap solution on a regular basis. Rinse with a spray bottle of clean water. Pat
D	<u>Acrylic Bread Bins / Bread Display Supports:</u> Clean out bread crumbs with a paper towel or clean cloth. Wipe off any smudges or fingerprints with mild soap and warm water solution and soft cloth.
W	<u>Magnetic Condenser Coil Filter (Self-Contained Units Only):</u> <ul style="list-style-type: none"> • This filter (accessible at case rear) helps prevent dust particles from entering condenser coil. • Clean magnetic condenser coil filter by following either of these steps: <ol style="list-style-type: none"> 1. As magnetic condenser coil filter is dishwasher safe, remove from case (no screw removal required) and use a rag or soft-bristled brush to wipe off excess dust particles from filter. Run in normal dishwasher cycle. Remove from dishwasher. Dry with soft cloth or paper towel. Return to case. 2. If NOT using dishwasher, remove magnetic condenser coil filter from case. Use a rag or soft-bristled brush to wipe off excess dust particles from filter. Submerge in warm, soapy water. Use soft-bristled brush to remove dust, dirt, grease and grime that may collect on filter. Rinse thoroughly. Dry with soft cloth or paper towel or allow to air dry. Replace.
W	<u>Model CO3434RG.5716 Salad Tissue Box Holder / Sandwich Wrap Holder:</u> <ul style="list-style-type: none"> • Clean with a mild soap and water solution and a soft cloth. Dry with paper towel or cloth. • For more thorough cleaning, remove from case rear (by lifting up and off). Submerge in warm soapy water and use a nylon brush to remove hardened residue. Rinse thoroughly. Dry with paper towel or soft, clean cloth. Return to case.
W	<u>Model CO3434RG.5716 Writing Instrument Cup:</u> <ul style="list-style-type: none"> • Remove from case rear (by lifting up and away from unit). Submerge in warm soapy water and use a nylon brush to remove hardened residue. Rinse thoroughly. Dry with paper towel or soft, clean cloth. Return to case.
W	<u>Model CO3434RG.5716 Sanitary Wipe Bucket:</u> <ul style="list-style-type: none"> • Remove from case rear (by lifting up and away from unit). • Submerge in warm soapy water and use a nylon brush to remove hardened residue. • Rinse thoroughly. Dry with paper towel or soft, clean cloth. Return to case.
M	<u>Night Air Curtain:</u> <ul style="list-style-type: none"> • Grasp handle, slowly raise curtain and attach to top panel (as shown in MAINTENANCE FUNDAMENTALS: NIGHT AIR CURTAIN OPERATING INSTRUCTIONS section in this manual for illustrations. • After curtain is fully extended, wipe down with warm soapy water and soft cloth. • After curtain has been wiped down, use spray bottle with clean water to spray surface of curtain (to remove soap residue) and dry with paper towel or soft, clean cloth. • Return night air curtain to its retracted position slowly and carefully.

GENERAL CLEANING (TO BE PERFORMED BY STORE PERSONNEL) - INTERIOR

NOTE: INSTRUCTIONS ARE FOR CASE INTERIOR ONLY (D=DAILY / W = WEEKLY / M = MONTHLY)

FREQ.	INSTRUCTIONS
D	<p>Decking, Rear Plenum: Clean with a warm soap and water solution. For stubborn stains/residue, TURN MAIN POWER SWITCH OFF. Remove deck and clean with soap and water solution or submersed in hot, soapy water solution. Rinse thoroughly. Dry. Return to case. Turn main power switch back on.</p>
D	<p>Product Display Risers/Steps (Optional): Remove steps for cleaning purposes.</p> <ul style="list-style-type: none"> • Light cleaning: Remove. Wipe with mild soap and water solution and soft cloth. • Severe cleaning: Remove and submerge in warm to hot water solution. Clean with soft cloth or non-metal brush.
D	<p>Glass Surfaces: Clean with household or commercial glass cleaner.</p>
W	<p>Air Return Grilles:</p> <ul style="list-style-type: none"> • Wipe off air return airflow grilles with moist cloth. • Return airflow grilles can be removed, submersed in warm, soapy water for more thorough cleaning. Rinse thoroughly before returning.
M	<p>Condenser Coil: Remove rear grille. Vacuum or brush grille condenser coil. Use metal or fiber brush to remove dust and dirt that can collect on condenser coils. Be careful not to damage the fins on the coil. See REFRIGERATION FUNDAMENTALS: ACCESS / CONNECTIONS / SERVICING section in this manual for instructions on rear grille removal.</p>

GENERAL CLEANING (TO BE PERFORMED BY TRAINED SERVICE PROVIDERS ONLY)

AREA TO CLEAN	FREQUENCY	INSTRUCTIONS
Case Interior	Monthly	<p>Evaporator Fan Shroud Area (Under Decking): <i>Caution! Due to rotating fans in area, turn off case and disconnect plug from wall outlet before beginning fan shroud (and surrounding tub area) cleaning!</i> 1) Turn off power. 2) Remove deck from case. 3) Clean fan shroud area (and surrounding tub area) with moist cloth.</p>
	Quarterly	<p>Tub & Drain: <i>Caution! Due to rotating fans in area, turn off case and disconnect plug from wall outlet before beginning tub & drain cleaning!</i> Vacuum tub under decks. Clean with soap and water solution. Wipe dry with clean cloth. Keep drain free of debris to prevent clogging.</p> <ul style="list-style-type: none"> Note: Fan shroud must be removed to access drain at center of tub.

CONDITION	TROUBLESHOOTING
Water Is On The Floor	Call service provider.
Fan Emits Excessive Noise	Call service provider.
No Case Lights Are Working	Check that light switch is in the <i>on</i> position.
	Check that ALL of the light cords and plugs are properly connected. See LED LIGHT FIXTURES: REPAIR / REMOVAL / REPLACEMENT section in this manual for specifics.
	Check circuit breaker box for tripped circuit.
	If case lights still do not come on, call service provider.
Case Light Is Not Working	Check that ALL of the light cords and plugs are properly connected. This includes the following items:
	<ul style="list-style-type: none"> • Oval form of plug must connect to oval form of LED light. • See MAINTENANCE FUNDAMENTALS - LED LIGHT FIXTURE / LOCATION / REPAIR / REPLACEMENT section in this manual for more specifics including illustrations.
	If case light still does not come on, call service provider.
Case is Not Holding Proper Temperature	If a large amount of warm product was added to the case, it will take time for the temperature to adjust. Product must be pre-chilled before placing in case.
	Check that the case is not in the sun or near a heat or air-conditioning vent. See OVERVIEW / TYPE / COMPLIANCE / WARNINGS / PRECAUTIONS / WIRING / PLUGS section in manual for specifics.
	If case is located near front doors, temperature fluctuation can hinder unit's ability to maintain temperature. See OVERVIEW / TYPE / COMPLIANCE / WARNINGS / PRECAUTIONS / WIRING / PLUGS section in this manual for specifics.
	Check that filter and condenser coil has been cleaned. See GENERAL CLEANING (TO BE PERFORMED BY STORE PERSONNEL) section in this manual for specifics.
	Check air return grilles (area at front of decking) for obstructions. DO NOT set product on air grilles as this will prevent proper airflow!
	If case still is not holding proper temperature, call service provider.

LED Style Light Fixtures

Removal of faulty LED light:

- LED lights rarely require change-out.
- To remove faulty LED light, simply grasp light near retaining spring and carefully pull away from its spring. Disconnect plug from LED's socket.
- Contact Structural Concepts' Technical Service Department for replacement parts (see Technical Service section of this manual for information).

Replacement of LED light:

- To replace LED light fixture, simply insert new LED light at proper position (socket must be near plug). Carefully snap into metal springs so LEDs are held firmly in place.
 - Note: LED light and plug must be connected in a specific manner or they will not work.
- A. Certain plug designs ("barrel type") merely require that plug be pushed all the way in.
 - B. Other plugs require "oval edge" of plug to connect to oval edge of LED light.
- See illustrations below.

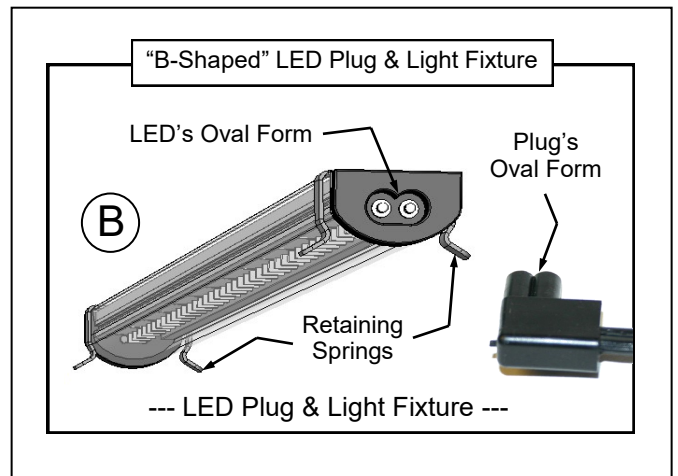
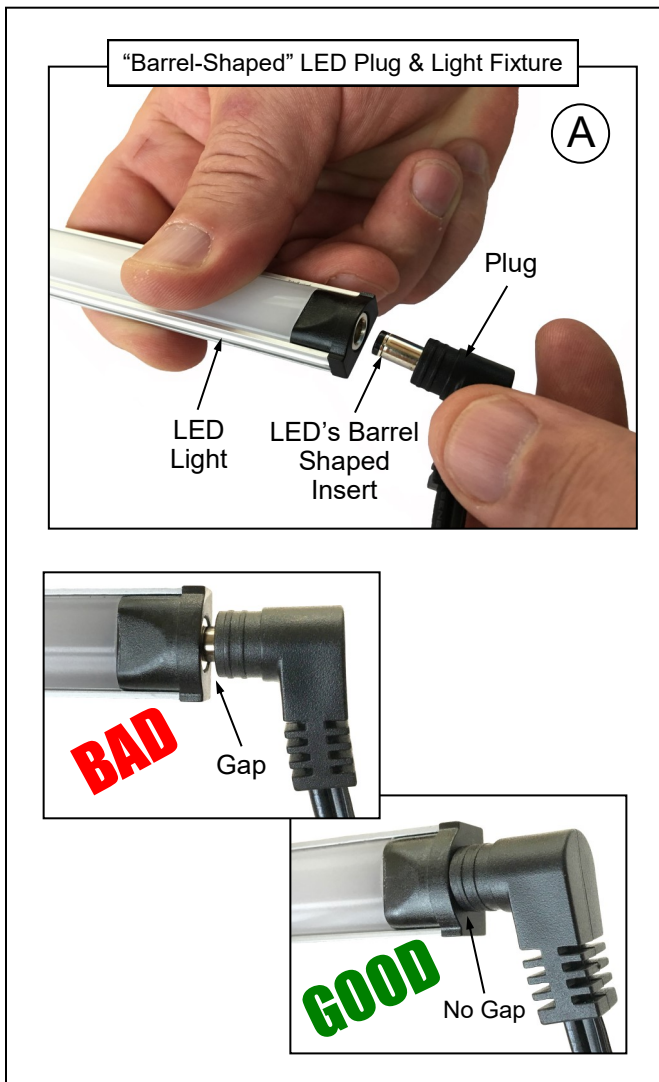

TROUBLESHOOTING (TO BE PERFORMED BY TRAINED SERVICE PROVIDERS ONLY)

CONDITION	TROUBLESHOOTING
Water Is On The Floor	Check that the drain trap is free of debris.
	Check that the drain hose is correctly positioned over evaporator pan.
	Check store conditions. <ul style="list-style-type: none"> • For Type 1 Conditions (most cases): ambient conditions are to be at 55% max. humidity / 75 °F. • For Type 2 Conditions: ambient conditions are to be at 55% maximum humidity / 80 °F.
	Check that the hot gas condensate pan is properly connected and heating.
	Wicking material (optional) may be dirty or worn and need replacement (hot gas loop condensate system). <ul style="list-style-type: none"> • Slide refrigeration system out from under unit. • After refrigeration system has been slid out from under unit, replace wicking material with new. If wicking material is not available, contact Structural Concepts®. See toll-free number at last page of this manual.
Fan Emits Excessive Noise	Check that the case is aligned, level and plumb.
	Check evaporator fan for cleanliness.
	Unplug/power off fan motor. Check motor shaft for bearing wear.
	Check that fan motor is securely mounted in bracket.
	Verify that fan blades are securely mounted to fan motor.
	Check that nothing is preventing blade rotation.
	Check that the fan shroud is properly secured.
Fan Is Not Working	Check that the MAIN power switch is on.
	Check that fan motor is plugged in at the fan shroud.
	Check for foreign material obstructing fan performance.
	Check that fan blades freely rotate within fan shroud.
	Check that power is going to fan.
	Check that fan wiring is connected on terminal blocks.
Digital Control Display Is Blank.	Check that the MAIN power switch is on.
	Check the circuit breaker box for tripped circuits.
System Not Operating	Check that the utility power is on.
	Check that the MAIN power switch is on.
	Check the circuit breaker box for tripped circuits.

TROUBLESHOOTING (TO BE PERFORMED BY TRAINED SERVICE PROVIDERS ONLY), CONTINUED

CONDITION	TROUBLESHOOTING
No Case Lights Are Working	Follow previous page's System Not Operating instructions.
	Check voltage at LED driver. If voltage is entering but not exiting, LED driver may be faulty.
	Check connection at case rear (from field wiring box) for voltage.
Case Light Is Not Working	Follow previous page's System Not Operating instructions.
	If case light still do not come on, call SCC Technical Service phone number (listed on last page of this operating manual).
Control Display Is Flashing	See your case's thermostat label (near temperature controller) for your model's required settings.
Case Is Not Holding Temperature	If a large amount of warm product was added to the case, it will take time for the temperature to adjust. Unit needs product to be pre-chilled.
	Temperature changes during defrost mode but will return to normal. Fourth LED (on temperature controller) will indicate defrost cycle in progress.
	Check that case is not in sun or near a heat or air-conditioning vent.
	If case is located near front doors, temperature fluctuation can hinder unit's ability to maintain temperature.
	Check that condenser coil has been cleaned.
	Check air grilles for obstructions.
	Check sight glass for flashing and/or low charge.
	Check Set Point Temperature; it may be adjusted too high.
Condensing Unit Is Not Operating	Check that the power is turned on.
	Determine if temperature controller settings are properly set. <i>See your case's serial label for your model's specified settings. See SERIAL LABEL LOCATION & INFORMATION LISTED / TECH INFO & SERVICE section in manual for label location, etc.</i>

TROUBLESHOOTING (BY TRAINED SERVICE PROVIDERS ONLY) - CONDENSING SYSTEM

CONDITION	TROUBLESHOOTING
Head Pressure Too High	Check that the condensing coil is not dirty or covered.
	Check that condensing fans are working.
	Check that refrigerant is not overcharged.
	Perform sub-cooling check and verify that no contaminants are in system.
	Check that liquid line filter dryer is not plugged.
	Check that close-offs are intact (around condensing coil) and that air is not recirculating.
	Check that store ambient temperature isn't above maximum allowed. See OVERVIEW / TYPE / COMPLIANCE / WARNINGS / PRECAUTIONS / WIRING / PLUGS section in this manual.
Head Pressure Too Low	Check if sight glass is flashing or showing low charge.
	Check that suction pressure isn't too low.
	Check that compressor reed valves aren't bad. Look for high suction/low head pressure. Perform pump down.

TROUBLESHOOTING (BY TRAINED SERVICE PROVIDERS ONLY) - EVAPORATOR SYSTEM

CONDITION	TROUBLESHOOTING
Low Suction Pressure	Check if sight glass is flashing or showing low charge.
	Check that expansion valve (TXV) isn't restricted. Check element charge.
	Check that liquid line or filter isn't restricted. Check that refrigeration lines and/or hoses are not kinked on either high or low sides.
	Check that evaporator fan motors are working.
	Check superheat.
	Check that there is no air recirculation around evaporator coil.
	Check that evaporator coil is not iced up.
High Suction Pressure	Check for refrigerant overcharge.
	Check that compressor reed valves aren't bad. Look for high suction/low head pressure. Perform pump down.
	Check that the "cooling load" isn't high. Product must be pre-chilled before placing in refrigerated section of case.
	Check that case is at least <u>15-feet</u> from exterior doors, overhead HVAC vents or any air curtain disruption.
	Check that unit is not exposed to direct sunlight via windows or any other heat source (ovens, fryers, etc.).
	Check that superheat adjustment isn't low.
	Check TXV bulb installation <ul style="list-style-type: none"> a. Poor thermal contact. b. Warm location.

PREVENTIVE MAINTENANCE (TO BE PERFORMED BY TRAINED SERVICE PROVIDERS ONLY)

WARNING! TURN OFF CASE BEFORE PERFORMING PREVENTIVE MAINTENANCE!

PREVENTIVE MAINTENANCE	FREQUENCY	INSTRUCTIONS
Case Exterior	Quarterly	<p><u>Condensing Coil:</u></p> <ul style="list-style-type: none"> • Remove rear grille (by lifting up and off). • Use air pressure or industrial strength vacuum; clean dust and dirt that may collect on the Condenser Coil. • Caution! Coil fins are sharp. Handle with care! • Replace rear grille to case.
	Quarterly	<p><u>Refrigeration Package/Compressor Area:</u> <i>Caution! Be certain to disconnect power from case before cleaning Refrigeration Package!</i></p> <ul style="list-style-type: none"> • <i>Warning! Condensate Pan Is HOT! Disconnect power from case and allow to cool before cleaning evaporator pan!</i> • Slide/Roll compressor package out from under case. • See REFRIGERATION FUNDAMENTALS section for in-depth instructions on accessing the evaporator pan. • Use a scrub-brush and a de-scaling solution such as CLR® (to prevent corrosion, lime and rust). Follow instructions as to proper dilution, safety precautions and scrubbing method. • After thoroughly cleaning pan with scrub-brush and solution, rinse thoroughly with clean water (in spray bottle) and wipe dry with sponge or paper towel. • Use moist cloth to wipe off dust & debris that collects on various parts (fans, sight glass, overflow pan, etc.). • Slide refrigeration assembly back under case. • Replace front panel and lower grille via hooks (no screws required).
	Quarterly	<p><u>Under Case Cleaning:</u> Once refrigeration package is clear of unit, vacuum under case to remove all dust and dirt that may collect under case.</p>
Case Interior	Quarterly	<p><u>Tub, Coil, Drain, Fans, Brackets:</u></p> <ul style="list-style-type: none"> • Remove decking. • Use vacuum to clean entire area. • After vacuuming, clean area with warm water, clean cloth, and mild soap solution. • Remove any debris that may clog drain.
	Quarterly	<p><u>Honeycomb:</u> Check honeycomb air diffuser to determine whether it is dirty. If dirty, remove from case. See PREVENTIVE MAINTENANCE: HONEYCOMB AIR DIFFUSERS (TRAINED SERVICE PROVIDERS ONLY) section of this manual (next page) for cleaning specifics.</p>

PREVENTIVE MAINTENANCE - HONEYCOMB (BY TRAINED SERVICE PROVIDERS ONLY)

1. Honeycomb Air Diffuser Removal

See **PREVENTIVE MAINTENANCE (TO BE PERFORMED BY TRAINED SERVICE PROVIDER)** section in this manual for cleaning frequency.

A. Wedge a non-metallic device of suitable strength (such as a ballpoint pen) between the honeycomb and the end panel.

Caution! Use care not to dislodge the heating wire (that prevents condensation on the lamp assembly).

B. Apply pressure to collapse the honeycomb to allow it to be pulled out of honeycomb retainer.

C. Carefully pry downward and away from the honeycomb retainer.

Clean honeycomb with warm water and soap solution. Submerge if necessary. Use brush to dislodge stubborn or sticky residue. Dry by using vacuum's blow mode (vs. suction mode).

2. Honeycomb Air Diffuser Installation

D. Squeeze honeycomb to allow it to fit into the honeycomb retainer.

E. Carefully slide honeycomb into place.

F. Adjust honeycomb so that it fits flat against retainer. It must not be wavy or out of position.

Note: For honeycomb air diffusers in other locations, these same general instructions apply.

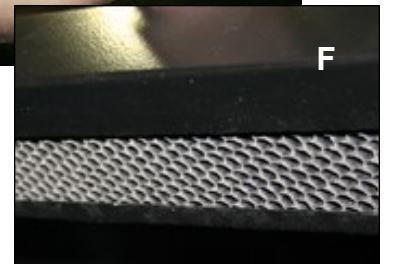
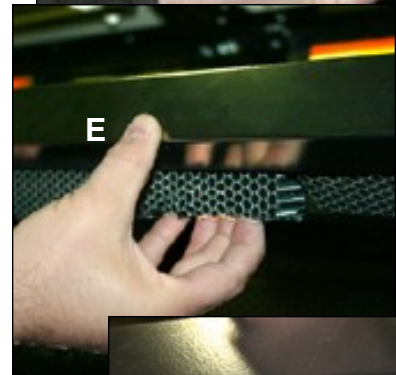
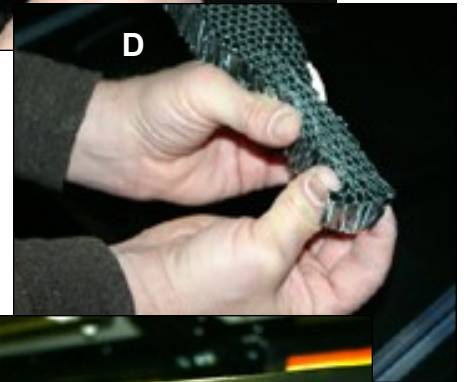
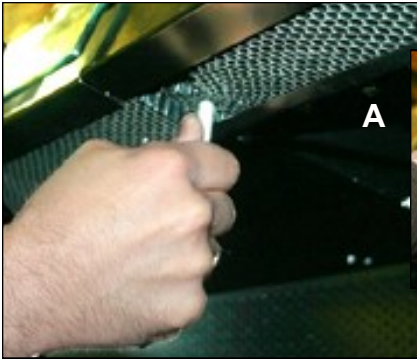



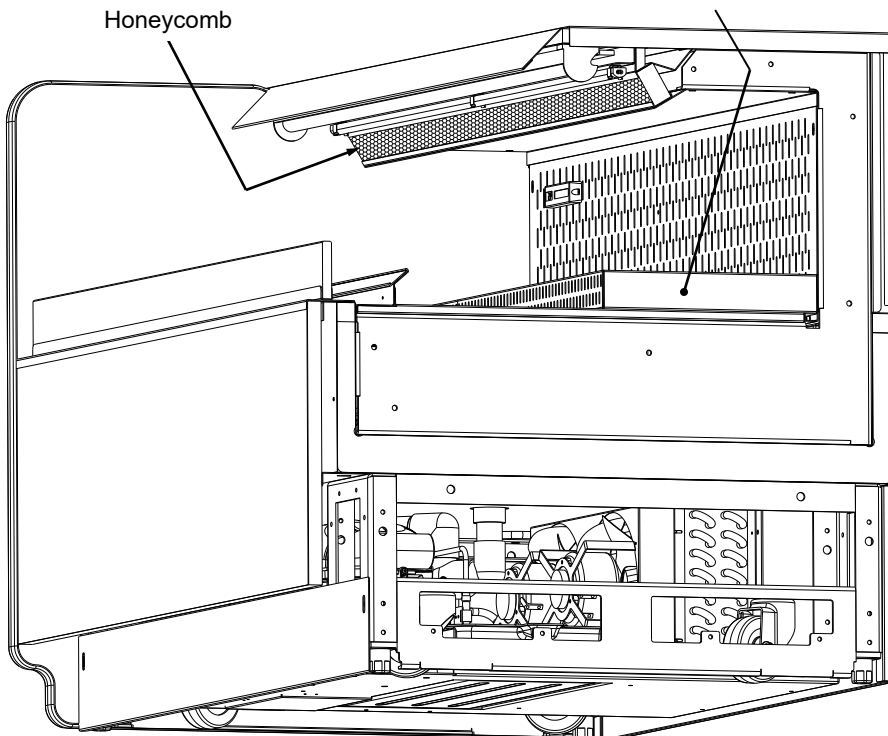

Optional Product Step (Not on All Cases) Shown For Illustrative Purposes Only



Serial Label Location & Information Listed / Technical Information & Service

- Serial labels are located near the electrical access on your case.
- Serial labels contain electrical, temperature & refrigeration information, as well as regulatory standards to which the case conforms.
- For additional technical information and service, see the *TECHNICAL SERVICE* page in this manual for instructions on contacting Structural Concepts' Technical Service Department.
- See image below for sample serial label.

 <p>Structural Concepts 888 E. Porter Rd · Muskegon, MI 49441</p>		 <p>ENCORE[®] SERIES MODEL HV74RSS SCROLL SERIAL NO.</p>	
<p>FOR PARTS AND SERVICE CALL 1-800-433-9489</p>		<p>SAMPLE ONLY</p>	
  <p>3048256</p>		<p>ELECTRICAL RATING 120/1/60 24A</p>	<p>REFRIGERANT R404A AMOUNT ?? OZ</p>
<p>CONFORMS TO UL STD 471</p>	<p>CONFORMS TO NSF STD 7</p>	<p>DESIGN PRESSURE HIGH 450 LOW 200</p>	<p>MINIMUM CIRCUIT 30A</p>
<p>CERTIFIED TO CAN/CSA STD C22.2 NO 120</p>		<p>MAXIMUM OVERCURRENT 30A</p>	
		<p>SAMPLE ONLY</p>	
<p>Super Heat Temp 8-10°F</p>		<p>SAMPLE ONLY</p>	
<p>BTUH Requirements 9,738 BTUH @ 20° F SST</p>			
<p>Defrost 6 defrosts per day, 45° F termination, 45 min. failsafe</p>			

----- Sample Serial Label For Refrigerated Case -----

CAREL

ir33 platform

Integrated Electronic
Microprocessor Controller



Programming The Instrument

To Modify The Setpoint

Set Press and hold the "SET" key for at least 1 second.

aux **def** 2. Use arrow keys ▲ ▼ on temperature controller to increase (or decrease) the setpoint.

Set 3. Quickly press and release the "SET" key again.

To Modify Defrost, Differential, Other Parameters

Prg **Set** 1. Press & hold "Prg" & "SET" keys together for five (5) seconds; display will flash "0", representing password prompt.

Set 2. Confirm by pressing "SET" key.

aux **def** 3. Press ▲ or ▼ to reach the category to be modified.

Set 4. Press "SET" to modify this selected parameter.

aux **def** 5. Increase or decrease the value using the ▲ or ▼ button respectively.

Set 6. Press the "SET" key to temporarily save the new value and return to the display of the parameter.

Prg **mute** 7. Press & hold the "Prg" key for at least 5 seconds to save changes. This action will also mute the audible alarm (buzzer) & deactivate the alarm relay.

Warning! Save Your Parameter Settings!

1. To store the new parameter values, PRESS and HOLD the "Prg" key for at least 5 seconds.
2. All modifications made to parameters will be lost if you do NOT press a button within 60 seconds. Should this "timeout" occur, normal operational settings (prior to modifications being made) will resume.
3. If the instrument is switched off before pressing the "Prg" key, all modifications to parameters will be lost.

def **▼** **To Activate Manual Defrost**
Press and hold "def" key for at least 5 seconds.

aux **▲** **To Activate / Deactivate Auxiliary Output**
Press and hold the "aux" key for 1 second.

Prg **▲** **To Reset Any Alarms With Manual Reset**
mute **aux**
Press and hold the "Prg" and "aux" key for at least 1 second.

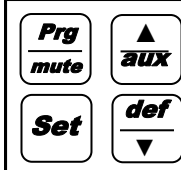

How To Change Reading From Fahrenheit (°F) To Celsius (°C)

Prg **Set** 1. Press and hold "Prg" and "SET" keys together for at least 5 seconds; display will show "0" (password prompt).

Set 2. Confirm by pressing "SET" key.

aux **def** 3. Press ▲ or ▼ until reaching the parameter "/ 5".

Set 4. Press "SET" to modify this selected parameter.

aux **def** 5. Press ▲ or ▼ to change value to desired setting: "0" for Celsius (°C) or "1" for Fahrenheit (°F).

Set 6. Press "SET" key to temporarily save the new value and return to the display of the parameter.

Prg **mute** 7. Press & hold "Prg" key for at least 5 seconds to save changes. **Note! All values will automatically convert to new scale. No conversion is required.**

CAREL

ir33 platform
**Integrated Electronic
 Microprocessor Controller**



User Interface - Display

ICON	FUNCTION	DESCRIPTION	ON	Normal operation OFF	BLINK	Start up
	COMPRESSOR	ON when the compressor starts. Flashes when the activation of the compressor is delayed by safety times.	Compressor on	Compressor off	awaiting activation	
	FAN	ON when the fan starts. Flashes when the activation of the fan is prevented due to external disabling or procedures in progress.	Fan on	Fan off	awaiting activation	
	DEFROST	ON when the defrost is activated. Flashes when the activation of the defrost is prevented due to external disabling or procedures in progress.	Defrost in progress	Defrost not in progress	awaiting activation	
	AUX	Flashes if the anti-sweat heater function is active, ON when the auxiliary output (1 and/or 2) selected as AUX (or LIGHT in firmware version 3.6) is activated.	AUX auxiliary output active (version 3.6 light auxiliary output active)	AUX auxiliary output not active	Anti-sweat heater function active	
	ALARM	ON following pre-activation of the delayed external digital input alarm. Flashes in the event of alarms during normal operation (e.g. high/low temperature) or in the event of alarms from an immediate or delayed external digital input.	Delayed external alarm (before the time 'A7' elapses)	No alarm present	Alarms in norm. operation (e.g. High/low temperature) or immediate or delayed alarm from external digital input	
	CLOCK	ON if at least one timed defrost has been set. At start-up, comes ON for a few seconds to indicate that the Real Time Clock is fitted.	If at least 1 timed defrost event has been set	No timed defrost event set	Alarm clock	ON if real-time clock present
	LIGHT	Flashes if the anti-sweat heater function is active, ON when the auxiliary output (1 and/or 2) selected as LIGHT is activated (in firmware version 3.6 it does not flash in anti-sweat heater mode and comes on when the dead band output is active).	Light auxiliary output on (version 3.6 dead band auxiliary output active)	Light auxiliary output off	Anti-sweat heater function active (version 3.6 does not flash in anti-sweat heater mode)	
	SERVICE	Flashes in the event of malfunctions, for example E2PROM errors or probe faults.		No malfunction	Malfunction (e.g. E2PROM error or probe fault). Contact service	
	CONTINUOUS CYCLE	ON when the CONTINUOUS CYCLE function is activated. Flashes if the activation of the function is prevented due to external disabling or procedures in progress (E.g.: minimum compressor OFF time).	CONTINUOUS CYCLE operation activated	CONTINUOUS CYCLE function not activated	CONTINUOUS CYCLE operation requested	

Summary Table of Alarm and Signals: Display, Buzzer and Relay

Code	Icon on the display	Alarm relay	Buzzer	Reset	Description
rE	flashing	on	on	automatic	virtual control probe fault
E0	flashing	off	off	automatic	room probe S1 fault
E1	flashing	off	off	automatic	defrost probe S2 fault
E2	flashing	off	off	automatic	probe S3 fault
E3	flashing	off	off	automatic	probe S4 fault
E4	flashing	off	off	automatic	probe S5 fault
'	No	off	off	automatic	probe not enabled
LO	flashing	on	on	automatic	low temperature alarm
HI	flashing	on	on	automatic	high temperature alarm
AFr	flashing	on	on	manual	antifreeze alarm
IA	flashing	on	on	automatic	immediate alarm from external contact
dA	flashing	on	on	automatic	delayed alarm from external contact
dEF	on	off	off	automatic	defrost running
Ed1	No	off	off	automatic/manual	defrost on evaporator 1 ended by timeout
Ed2	No	off	off	automatic/manual	defrost on evaporator 2 ended by timeout
Pd	flashing	on	on	automatic/manual	maximum pump down time alarm
LP	flashing	on	on	automatic/manual	low pressure alarm
AtS	flashing	on	on	automatic/manual	autostart in pump down
cht	No	off	off	automatic/manual	high condenser temperature pre-alarm
CHT	flashing	on	on	manual	high condenser temperature alarm
dor	flashing	on	on	automatic	door open too long alarm
EE	flashing	off	off	automatic	E?prom error, unit parameters
EF	flashing	off	off	automatic	E?prom error, operating parameters
ccb	Signal				start continuous cycle request
ccE	Signal				end continuous cycle request
dFb	Signal				start defrost call
dFE	Signal				end defrost call
On	Signal				switch ON
off	Signal				switch OFF
rES	Signal				reset alarms w/manual reset / reset HACCP alarms / reset temp. monitoring

CAREL

ir33 platform

Integrated Electronic
Microprocessor Controller



Summary Table of Operating Parameters

CODE	PARAMETER	UOM*	TYPE	MINIMUM	MAXIMUM	DEFAULT
/5	Select Celsius (°C) or Fahrenheit (°F)	flag	C	0	1	For Case Specific Defaults See Serial Label Located Near Electrical Access On Your Case. For Additional Technical Information Call Structural Concepts Technical Service Dept. at 1(800) 433.9489
/c1	Calibration of probe 1	°C/°F	C	-20	20	
/c2	Calibration of probe 2	°C/°F	C	-20	20	
St	Temperature set point	°C/°F	F	r2	r1	
rd	Control delta	°C/°F	F	20	0.1	
dl	Interval between defrosts	hours	F	0	250	
dt1	End defrost temperature, evaporator	°C/°F	F	-50	200	
dP1	Maximum defrost duration, evaporator	min	F	1	250	
d6	Display on hold during defrost	-	C	0	2	
dd	Dripping time after defrost	min	F	0	15	
d/1	Display of defrost probe 1	°C/°F	F	-	-	

* Unit Of Measure

STRUCTURAL CONCEPTS TECHNICAL SERVICE CONTACT INFORMATION & LIMITED WARRANTY

TECH SERVICE/WARRANTY CONTACT INFO: 1 (800) 433-9490 / EXTENSION 1

DAYS/HOURS AVAILABLE:
MONDAY - FRIDAY (CLOSED HOLIDAYS)
8:00 a.m. TO 5:00 p.m. EST

YOU MUST HAVE THE FOLLOWING INFO AVAILABLE BEFORE CONTACTING STRUCTURAL CONCEPTS:

SERIAL NO. / MODEL NO. / STORE NO. / STORE
ADDRESS / DETAILS (PHOTOS, LEAK LOCATIONS,
DAMAGE, STORE'S AMBIENT CONDITIONS, ETC.)

LIMITED WARRANTY

Overview: All sales by Structural Concepts Corporation (hereafter referred to as "SCC") are subject to the following limited warranty. "Goods" refers to the product or products being sold by SCC.

Warranty Scope: Warranty is for equipment sold in the United States, Canada, Mexico and Puerto Rico. Equipment sold elsewhere may carry modified warranties.

Warranty; Remedies; Limitations: The limit of liability of SCC toward the exchange cost of the original compressor motor (and/or any other components) is one year parts and labor. If any Goods are found to be of faulty material or workmanship within one year of the original F.O.B. (free on board) unit shipment, SCC will, at its option (after inspection by an authorized representative), replace or pay the reasonable cost of replacement of the faulty Goods. If warranty claim is not made within this one year time period, SCC is not bound to warrant Goods. A motor-compressor (and/or any other components) replaced during the warranty shall not exceed manufacturer's current established wholesaler's exchange price. If replacement motor-compressor (and/or other components) is available via storage facility, parts truck, etc., SCC mandates that readily accessible replacement components be used toward repair of Goods; in such instances, SCC will replace such equipment (at its own expense) after confirmation of its use/placement on defective unit. SCC shall not be charged an additional fee, up-charge or expense for such replacement Goods. If SCC is unable to repair or replace the defective Goods, SCC shall issue a credit to the Purchaser for full or partial purchase price, as SCC shall determine. The replacement or payment in the manner described above shall be the sole and exclusive remedy to Purchaser for a breach of this warranty. If any Goods are defective or fail to conform to this warranty, SCC will furnish instructions for their disposition. No Goods shall be returned to SCC without its prior consent.

SCC's liability for any defect in the Goods shall not exceed the purchase price of the Goods. SCC SHALL HAVE NO LIABILITY TO PURCHASER FOR CONSEQUENTIAL DAMAGES OF ANY KIND WHATSOEVER, INCLUDING, BUT NOT LIMITED TO, PERSONAL INJURY, PROPERTY DAMAGE, LOST PROFITS, OR OTHER ECONOMIC INJURY DUE TO ANY DEFECT IN THE GOODS OR ANY BREACH OF SCC, SCC SHALL NOT BE LIABLE TO THE PURCHASER IN TORT FOR ANY NEGLIGENT DESIGN OR MANUFACTURE OF THE GOODS, OR FOR THE OMISSION OF ANY WARNING THEREFROM.

SCC shall have no obligation or liability under this warranty for claims arising from any other party's (including Purchaser's) negligence or misuse of the Goods or environmental conditions. This warranty does not apply to any claim or damage arising from or caused by improper storage, handling, installation, maintenance, or from fire, flood, accidents, structural defects, building settlement or movement, acts of God, or other causes beyond SCC's control.

Except as expressly stated herein, SCC makes no warranty, express, implied, statutory or otherwise as to any parts or goods not manufactured by SCC. SCC shall warrant such parts or Goods only (I) against such defects, (II) for such periods of time, and (III) with such remedies, as are expressly warranted by the manufacturer of such parts of Goods. Notwithstanding the foregoing, any warranty with respect to such parts of Goods and any remedies available as a result of a breach thereof shall be subject to all of the procedures, limitations, and exclusions set forth herein.

THE WARRANTIES HEREIN ARE IN LIEU OF ALL WARRANTIES, EXPRESS, IMPLIED, STATUTORY, OR OTHERWISE. IN PARTICULAR, SCC MAKES NO WARRANTY OF MERCHANTABILITY OR FITNESS FOR A PARTICULAR PURPOSE.

No representative, agent or dealer of SCC has authority to modify, expand, or extend this Warranty, to waive any of the limitations or exclusions, or to make any different or additional warranties with respect to Goods.

Period of Limitations: No claim, suit or other proceeding may be brought by Purchaser for any breach of the foregoing warranty or this Agreement by SCC or in any way arising out of this Agreement or relating to the Goods after one year from the date of the breach. In the interpretation of this limitation on action for a breach by SCC, it is expressly agreed that there are no warranties of future performance of the goods that would extend that period of limitation herein contained for bringing an action.

Indemnifications: Purchaser agrees to indemnify, hold harmless, and defend SCC if so requested, from any and all liabilities, as defined herein, suffered, or incurred by SCC as a result of, or in connection with, any act, omission, or use of the Goods by Purchaser, its employees or customers, or any breach of this Agreement by Purchaser. Liabilities shall include all costs, claims, damages, judgments, and expenses (including reasonable attorney fees and costs).

Remedies of SCC: SCC's rights and remedies shall be cumulative and may be exercised from time to time. In a proceeding or action relating to the breach of this Agreement by Purchaser, Purchaser shall reimburse SCC for reasonable costs and attorney's fees incurred by SCC. No waiver by SCC of any breach of Purchaser shall be effective unless in writing nor operate as a waiver of any other breach of the same term thereafter. SCC shall not lose any right because it has not exercised it in the past.

Applicable Law. This Agreement is made in Michigan; it is governed by and interpreted according to Michigan law. Any lawsuit arising out of this Agreement or the Goods may be handled by a federal or state court whose district includes Muskegon County, Michigan, and Purchaser consents that such court shall have personal jurisdiction over Purchaser.

LED Lighting Components Within Lighting System: Supermarket: 5-year LED warranty from date of shipment. **Foodservice:** 2-year LED warranty from date of shipment. After one year, warranty does not include labor or other costs incurred for diagnosing, repairing, removing, installing, shipping, servicing, or handling of either defective part or replacement parts. Remedy of repair or provision of a replacement part without charge shall be the exclusive remedy for any warranty claim. The replacement LED and/or power supply assumes the unused portion of warranty remaining on unit(s). A 90-day warranty will apply for any LED sold as a service part. Warranty claim must include serial and model number of unit as well as date code on defective LED lighting component(s). Manufacturer may request return of defective part(s) at customer's expense to initiate claim.

Glass Material: Glass (UV-bonded glass, glass sneeze guards, glass enclosures, glass held in place via posts, etc.) is only warranted to FIRST POINT OF DELIVERY.

Miscellaneous: If any provision of this Agreement is found to be invalid or unenforceable under any law, the provision shall be ineffective to that extent and for the duration of the illegality, but the remaining provisions shall be unaffected. Purchaser shall not assign any of its rights nor delegate any of these obligations under this Agreement without prior written consent of SCC. This Agreement shall be binding upon and inure to the benefit of SCC and Purchaser and each of their legal representatives, successors and assignees. SCC warrants its products to be free of defects in materials and workmanship under normal use and service for a period of one (1) year from the date of delivery.

This warranty is extended only to the original purchaser for use of the Goods. It does not cover normal wear parts such as plastic tongs, tong holders, tong cables, bag holders, or acrylic dividers.

General Conditions: All service labor and/or parts charges are subject to approval by SCC. Contact Customer Service Dept. in writing, by phone, fax or email.

All claims must contain the following information: (1) model & serial code number of equipment; (2) the date and place of installation; (3) the name and address of the agency which performed the installation; (4) the date of the equipment failure; and (5) a complete description of the equipment failure and all circumstances relating to that failure.

Once the claim has been determined to be a true warranty claim by SCC's Customer Service Department, the following procedure will be taken: (1) replacement parts will be sent at no charge from SCC on a freight prepaid basis; (2) reimbursement for service labor will be paid if the following conditions have been met - (a) prior approval of service agency was awarded from the Customer Service Department; and (b) an itemized statement of all labor charges incurred is received by the Customer Service Department. The cost of the service labor reimbursement will be based on straight time rates and reasonable time for the repair of the defect.

If problems occur with any compressor, notify SCC's Customer Service Department immediately. Any attempt to repair or alter the unit without prior consent from the Customer Service Department will render any warranty claim null and void. This warranty and protection plan does not apply to any condensing unit or any part thereof which has been subject to accident, negligence, misuse, or abuse, or which has not been operated in accordance with the manufacturer's recommendations or if the serial number of the unit has been altered, defaced, or removed.

One Year Limit of Liability: After SCC's one-year parts and labor warranty on the original F.O.B. (free on board) unit has expired, SCC is not liable for either the equipment or labor costs of repairing or replacing the motor compressor, nor any other components that were included in the original F.O.B. (free on board) unit.